



Instructions for Use

AEROSPRAY[®] HEMATOLOGY STAT

SLIDE STAINER/CYTOCENTRIFUGE

MODEL 7122

AEROSPRAY® HEMATOLOGY STAT

SLIDE
STAINER/CYTOCENTRIFUGE

Model 7122

Instructions for Use

BMS-57-2000-03A

REF

Last Revision 2026-02-10

©2026 ELITechGroup Inc. All rights reserved. Printed in the United States of America. No part of this publication may be reproduced, transmitted, transcribed, stored in a retrieval system, or translated into any language (human or computer) in any form, or by any means whatsoever, without the prior express written permission of ELITechGroup Inc.

Aerospray® and Cytopro® are trademarks of ELITechGroup Inc.

Other trade names used in these instructions are trademarks of their respective owners, used here for information only.

ELITechGroup Inc. makes no express or implied warranty regarding these instructions, its quality, performance, or appropriate use regarding any type of specific procedure. ELITechGroup Inc. may modify these instructions without notice and without implying any obligation or liability on the part of the company.

Manufactured in the United States of America



ELITechGroup Inc.

370 West 1700 South
Logan, Utah 84321 USA

Telephone:

800 453 2725 (United States & Canada)
(+1) 435 752 6011 (International)

Fax:

(+1) 435 752 4127

Email:

Service.bms@bruker.com



Table of Contents

Section 1: Introduction

1.1 Instrument Overview	7
Using these Instructions	7
Functional Description	8
Key Features	9
Intended Use	9
Table 1: General Specifications	10
Table 2: Performance Specifications	11
Table 3: Run Time Sequence	12
Table 4: Approximate Reagent Consumption	12
Table 5: Carousel and Rotor Information	13
Table 6: Explanation of Symbols	14
1.2 Instrument Description	17
Figure 1: Front and Right-Side Panels	17
Figure 2: Front Panel and Touchscreen	18
Figure 3: Rear Panel	18
Figure 4: Stainer Bowl Components	19
Figure 5: Nozzle Diagram	19
Table 7: Preventive Maintenance Kit	20
1.3 Touchscreen and User Interface	22
Table 8: Front Panel/Main Screen Function Keys	22
Table 9: System Setup Keys	23
Table 10: Maintenance Function Keys	24

Section 2: Setup and Preparation for Operation

2.1 Instrument Setup	25
Unpacking and Installing the Stainer	25
Connecting the Drain Tube and Waste Container	26
Connecting Power	26
Installing Reagent Bottles	27
Installing the Optional Barcode Reader	27
2.2 Preparing the Stainer for Operation	28
Priming Procedures	28
The Clean Cycle	30
Performing Tests	30
Reagent Level Monitoring	31
Table 11: Reagent Level Detect Display Symbols	31
Enabling/Disabling Reagent Level Detect	32
Zeroing the Reagent Level Sensors	33

Section 3: Controlling and Customizing Stainer Functions

3.1 System Setup Menu	35
Accessing the System Setup Menu	35
Stain Programs	35
Creating a Stain Program	36
Editing, Renaming, or Adjusting Stain Programs	37
Administrator and User Accounts	38
Creating an Administrator Account	38

Table of Contents

Section 3: Controlling and Customizing Stainer Functions (continued)

Creating User Accounts	39
Managing User Access.....	40
User Login/Logout	40
Using Reagent Information Tracking	42
Modifying Level Detect Functions	42
Changing User Language	43
Setting the Date and Time.....	43
System Log	43
Accessing Logs	43
Exporting Logs	43
Controlling Beeper Alerts	44
QC/Maintenance Tracking.....	44
Enable Stain Slide Tracking	45
Enable Cyto Slide Tracking.....	46
Enable Manual Entry	46
Enable Preventive Maintenance Tracking	46
Enable Reagent Tracking	46
Restoring Software Defaults.....	47
3.2 Recording Specimen and Reagent Information.....	48
Scanning Slides with the Barcode Reader	48
Scanning Reagent Bottles with the Barcode Reader	49
Manually Entering Specimen information.....	50
Manually Entering Reagent Information	51
3.3 The Help Menu.....	52
Using Help	52

Section 4: Operating the Stainer

4.1 Operating Instructions	53
Suggested Staining Protocol.....	53
Checking Reagent and Waste Levels	53
Replacing a Reagent Bottle	53
Emptying the Waste Container	54
Loading the Carousel	54
Figure 6: Specimen Placement on Slide.....	56
Figure 7: Loading the Carousel	56
Using Blocking Slides	57
Figure 8: Using Blocking Slides	57
Performing a Stain Cycle	57
Unloading the Carousel	58

Section 5: Preventive Maintenance and Safety

5.1 Preventive Maintenance	59
Daily Maintenance/Quality Control (QC)	59
Weekly Maintenance	59
Monthly Maintenance.....	60
Annual Maintenance	60
Using the Preventive Maintenance Log.....	60
5.2 Storing the Instrument.....	61
Preparing for Long-Term Storage	61
Preparing for Operation After Storage	61
5.3 Replacing Fuses	62
5.4 Cleaning the Stainer and Carousels.....	63
Cleaning Liquid Spills	63
Cleaning Broken Slides	63

Table of Contents

Section 5: Preventive Maintenance and Safety (continued)

5.5 Decontaminating the Stainer and Carousels.....	64
Solutions for Decontaminating the Instrument.....	64
Decontaminating the Instrument.....	64
Figure 9: Lid Latch and Locking Pin Hole Locations	65
Decontaminating Reagent Bottles.....	66
5.6 Shipping or Disposing of the Stainer or Carousels.....	66
Shipping the Instrument or Carousels.....	66
Hazard-Free Certification	66
Disposing of the Instrument or Carousels	66

Section 6: Nozzle Maintenance and Performance

6.1 Nozzle Disassembly and Cleaning.....	67
Nozzle Disassembly	67
Nozzle Cleaning	67
6.2 Nozzle Reassembly	68
6.3 Manual Priming	69
6.4 Performing the Volume Test	70
Table 12: Volume Test Tolerances.....	70
6.5 Performing the Slide Pattern Test	71
Figure 10: Correct Slide Pattern Test Result.....	71
Figure 11: Incorrect Slide Pattern Test Result	71
6.6 Performing the Hub Pattern Test	72
Figure 12: Correct Hub Pattern Test Result.....	72
Figure 13: Incorrect Hub Pattern Test Result	72

Section 7: Solving Problems

7.1 Troubleshooting	73
Table 13: General Troubleshooting and Diagnosis	73
7.2 Abnormal Staining Results	78
Smear Separation or Tearing.....	78
Improper Alcohol Fixation	78
Wet Smears	78
Thick Smears.....	78
Dirty Slides.....	78
Red Cell Artifacts	78
False-Positive Howell-Jolley Bodies or Amorphous Precipitates.....	79
7.3 Instrument Malfunction	80
Inconsistent Reagent Flow	80
Reagent Level Detect System Errors	81
7.4 Calibrating the Touchscreen.....	83
7.5 Service Information	84

Table of Contents

Section 8: Cytopro® Cytocentrifuge

8.1 Cytopro Cytocentrifuge Information	85
Functional Description	85
Key Features	85
Intended Use	85
Appendix A: Critical Reagent Components	86
Appendix B: Stain Information	88
Appendix C: Accessories and Supplies	89
Appendix D: Cleaning Solutions	90
Revision History Table	92

SECTION 1 INTRODUCTION

1.1 Instrument Overview

Using these Instructions

These instructions for use (also referred to as an IFU) provide information on how to install, operate, and maintain the Aerospray Hematology Stat Stainer/Cytocentrifuge. The IFU is an important part of the product. Read it carefully and completely before setup and first use of the instrument.

If additional accident prevention and environmental protection requirements exist in the country of operation, this IFU must be supplemented by appropriate instructions to ensure compliance.

Safety Regulations

This instrument has been built and tested in accordance with safety regulations for the following device types: electrical control, regulating, and laboratory. In order to maintain this condition and ensure safe operation, the operator must observe all the instructions and warnings contained in this IFU. For current information about applicable standards, please refer to the CE Declaration of Conformity included with the documents shipped with this device.

NOTE: *This equipment complies with the emission and immunity requirements described in the IEC 61326 series.*

Understanding Warnings

This IFU uses three warning levels to alert you to important information as shown in the following examples.



WARNING!

A Warning alerts to the possibility of personal injury, death, or other serious adverse reactions stemming from the use or misuse of this device or its components.



CAUTION:

A Caution alerts to possible problems with the device associated with its use or misuse. Such problems include device malfunction, failure, damage, damage to the sample, or damage to other property. Where applicable, a Caution may include precautions to be taken to avoid the hazard.

NOTE: *A Note reinforces or supplies additional information about a topic.*

Specific Warnings

Pay particular attention to the following safety precautions. If these safety precautions are ignored, injury or damage to the instrument may occur. Each individual precaution is important.



WARNING!

Install the stainer in a well-ventilated area. If ventilation is inadequate, operate the instrument under a safety hood.

SECTION 1 INTRODUCTION

1.1 Instrument Overview



WARNING!

Reagents used in the stainer contain moderately hazardous chemicals that require care in handling. Always use appropriate safety measures including gloves and eye protection when handling reagents.



WARNING!

Always wear protective clothing and eye protection when using Nozzle Cleaning Solution (diluted SS-029C) and Stain Residue Solvent (SS-230). Dispose of used solution properly.



WARNING!

If power is lost while the stainer is running, the lid will remain locked until power is restored. Do not attempt to open the lid while power is off.



WARNING!

Electrical shock hazard: Do not open this instrument or attempt internal repairs without guidance from Bruker Biomedical Systems' Service Team. Refer servicing to qualified service personnel.



CAUTION:

This equipment has been designed and tested to CISPR 11 Class A and FCC Part 15 Class A. In a domestic environment it may cause radio interference, in which case, you may need to take measures to mitigate the interference.



CAUTION:

To avoid serious instrument damage, always use reagents supplied by Bruker. Using reagents not supplied by Bruker may void the warranty.



CAUTION:

Only spare parts supplied or specified by Bruker should be used in this instrument. Using non-approved parts may affect the performance and safety features of the instrument. If the instrument is used in a manner not specified by Bruker the protection provided by the instrument may be impaired.

Functional Description

The Aerospray Hematology Stat Slide Stainer/Cytocentrifuge (Model 7122) is a dual-purpose, microprocessor-controlled slide staining and cell preparation system using Wright-Giemsa staining techniques. In use, atomizing spray nozzles apply fresh reagents onto microscope slides prepared with blood or other body fluid specimens. The slides are mounted in a rotating carousel for processing. Near the end of the staining cycle, after purging the lines and rinsing the slides with methanol, the slides are rapidly dried by high-speed carousel rotation.

1.1 Instrument Overview

Key Features

- Minimized reagent consumption
- Rapid staining
- Eliminates cross-contamination
- Barcode scanner for tracking specimens and reagents
- Reagent and specimen traceability
- User traceability
- Administrator password
- Interactive touchscreen display
- Multiple languages
- High-volume staining productivity (12 slides per stain cycle)
- Separate reservoir, delivery tube, and pump for each reagent
- Operator-selectable automatic alcohol fixation function to fix specimens
- Reagent and waste level monitoring
- Reagent and QC tracking
- Stain program customization

The correct accessory must be used for each function. The Cytopro® Cytocentrifuge Rotor is available as an option offering additional features (see Section 8).

Intended Use

The Aerospray Hematology Stat Slide Stainer/Cytocentrifuge (Model 7122) is intended for use by medical professionals to stain specimens that may include blood and other body fluids, as a step of standard laboratory practice in diagnosing disease. Addition of the Cytopro rotor allows preparation of slides by cytocentrifugation before staining.

SECTION 1
INTRODUCTION

1.1 Instrument Overview

Table 1: General Specifications

Category	Characteristics
Slide Carousel Capacity	1 to 12
Carousel Rotation Speed	From 10 to 1,000 rpm (pre-programmed). 100 rpm to 1,000 rpm \pm 5%. 10 rpm to 99 rpm \pm 2 rpm.
Cytocentrifuge Rotor Speed	100 to 2,000 rpm (\pm 5%), user programmable
Reagent Consumption	Refer to Table 4: Approximate Reagent Consumption
Operating Time	Refer to Table 3: Run Time Sequence
Display	7 in. LCD WVGA (800 x 480 pixels) TFT
Touchscreen Controls	Numeric and alpha-numeric programming keys
Drain Connection	Connector on rear panel accepts male connector attached to 3/8 in. ID vinyl drain tube. 1.8 meters (6 ft.) length supplied
Ventilation	Air is exhausted from the stainer via a female ½ inch SAE pipe thread fitting to allow connection to ventilation systems
Dimensions Width Height (lid closed) Depth Height (lid open)	57 cm (22 in.) 25 cm (10 in.) 54 cm (21 in.) 58 cm (23 in.)
Weight	16.3 kg (35.9 lb.) – unpacked 21.4 kg (47.2 lb) – packed
Electrical Requirements	100 to 240 VAC (\pm 10%) @ 50 to 60 Hz
Power Consumption	200 VA
Fuses	Fuses (quantity 2): T2A250V~
Ambient Temperature Operating Storage	15 to 30° C (59 to 86° F) -10 to 50° C (14 to 122° F)
Relative Humidity	\leq 80% non-condensing
Altitude	\leq 2,000 m (\leq 6,562 ft.)

SECTION 1
INTRODUCTION

1.1 Instrument Overview

Table 1: General Specifications (continued)

Category	Characteristics
Pollution Degree	2
Heat Dissipation Maximum Average During Staining Average While Idle	150 Watts (512 Btu/hour) 30 Watts (102 Btu/hour) 12 Watts (41 Btu/hour)
Maximum Sound Emission	Adjustable: maximum 60 dB (SPL) intensity at 1 m and < 80 dB (typically 72 dB)

Table 2: Performance Specifications

Category	Characteristics
Reagent Spray Nozzles	Four reagent nozzles: A, B, C, D
Reagents: <i>NOTE: Use only Bruker reagents, with diluents as specified for Bruker concentrated reagents. REF numbers for this stainer start with one of the following: SS-035, SS-049, SS-135, SS-149, SS-048, or SS-148.</i>	A - Rinse B – Thiazin Stain (Blue) C – Eosin Stain (Red) D – Methanol or Aerofix® <i>Note: Methanol must be 99.5% pure no more than 0.5% water.</i>
Stain Settings	<ul style="list-style-type: none"> • Number of slides to stain • Intensity settings: 1-10 • Fixation level: Off, Normal, High

SECTION 1

INTRODUCTION

1.1 Instrument Overview

Table 3: Run Time Sequence

NOTE: Table 3 represents a typical timing sequence for this instrument using the 12-slide carousel, presented for general reference only. Timing is in seconds. Actual cycle times may vary.

Sequence Step	Medium Dark Setting (5)
Fixation (Optional)	(102)
Eosin Stain	21
Thiazin Stain	33
Rinse	27
Drying	33
Total without fixation (in minutes)	1.9
Total with fixation (in minutes)	3.6

Table 4: Reagent Consumption

NOTE: Table 4 represents approximate reagent consumption for this instrument using the 12-slide carousel, presented for general reference only. Consumption is in milliliters. Actual consumption volume may vary.

Reagent	Medium Dark Setting (5)	Clean Cycle
Reagent A: Rinse	6.0	7.5
Reagent B: Thiazin	6.0	7.5
Reagent C: Eosin	6.0	7.5
Reagent D: Fixative	1.4	38.0

SECTION 1
INTRODUCTION

1.1 Instrument Overview

Table 5: Carousel and Rotor Information











Only the following slide staining carousel or cytocentrifuge rotor can be used in this instrument. Each should be used following the instructions in this IFU or the Cytopro® Instructions for Use (RP-517).















Rotor/Carousel	Maximum Capacity
12-Slide Carousel (AC-188)	12 each, 26 mm x 76 mm (1 x 3 inch) microscope slides
Cytopro Cytocentrifuge Rotor (AC-160)	8 chambers, plus slides











SECTION 1 INTRODUCTION

1.1 Instrument Overview

Table 6: Explanation of Symbols

SYMBOL	STANDARD REFERENCE	STANDARD TITLE	SYMBOL TITLE	SYMBOL MEANING
	IEC 60601- 1 Reference no. Table D1, Symbol 8 (IEC 60417-5032)	Medical electrical equipment — Part 1: General requirements. for basic safety and essential performance	Alternating current	To indicate on the rating plate that the equipment is suitable for alternating current only; to identify relevant terminals
	ISO 15223-1: 2021 Reference no. 5.1.2	Medical devices — Symbols to be used with information to be supplied by the manufacturer - Part 1: General requirements.	Authorized Representative in the European Community/ European Union	Indicates the authorized representative in the European Community / European Union
	MU600_00_016e V3.0	Information Sheet Obligations Economic Operators CH	Swiss Authorized Representative	Indicates the authorized representative in Switzerland
	ISO 15223-1: 2021 Reference no. 5.1.5. (ISO 7000-2492)	Medical devices — Symbols to be used with information to be supplied by the manufacturer - Part 1: General requirements.	Batch code	Indicates the manufacturer's batch code so that the batch or lot can be identified. Synonyms for "batch code" are "lot number", "lot code" and "batch number".
	ISO 15223-1:2021 reference no. 5.4.1 (ISO 7010 – W009)	Medical devices — Symbols to be used with information to be supplied by the manufacturer - Part 1: General requirements.	Warning; Biological hazard	Bio-contamination warning
	ISO 15223-1: 2021 Reference no. 5.1.6. (ISO 7000-2493)	Medical devices — Symbols to be used with information to be supplied by the manufacturer - Part 1: General requirements.	Catalogue number Catalog number	Indicates the manufacturer's catalog number so that the medical device can be identified ISO 15223 Catalogue number ISO 7000 Catalog number
	ISO 15223-1: 2021 Reference no. 5.4.4. (ISO 7000-0434A)	Medical devices — Symbols to be used with information to be supplied by the manufacturer - Part 1: General requirements.	Caution	To indicate that caution is necessary when operating the device or control close to where the symbol is placed, or to indicate that the current situation needs operator awareness or operator action in order to avoid undesirable consequences
	EU 2017-746 Reference no. ANNEX V	REGULATION (EU) 2017/746 OF THE EUROPEAN PARLIAMENT AND OF THE COUNCIL of 5 April 2017 on in vitro diagnostic medical devices and repealing Directive 98/79/ EEC and 2010/227/EU	CE marking	(43) 'CE marking of conformity' or 'CE marking' means a marking by which a manufacturer indicates that a device is in conformity with the applicable requirements set out in this Regulation and other applicable Union harmonization legislation providing for its affixing
	ISO 15223-1:2021 Reference no. 5.4.3. (ISO 7000-1641)	Medical devices — Symbols to be used with information to be supplied by the manufacturer - Part 1: General requirements.	Consult instructions for use or consult electronic instructions for use	Indicates the need for the user to consult the instructions for use
	ISO 15223-1:2021 Reference no. 5.4.2. (ISO 7000- 1051)	Medical devices — Symbols to be used with information to be supplied by the manufacturer - Part 1: General requirements.	Do not re-use	Indicates a medical device that is intended for one single use only NOTE: Synonyms for "Do not reuse" are "single use" and "use only once".

SYMBOL	STANDARD REFERENCE	STANDARD TITLE	SYMBOL TITLE	SYMBOL MEANING
	ISO 15223-1: 2021 Reference no. 5.2.8. (ISO 7000-2606)	Medical devices — Symbols to be used with information to be supplied by the manufacturer - Part 1: General requirements.	Do not use if package is damaged and consult instructions for use	Indicates a medical device that should not be used if the package has been damaged or opened and that the user should consult the instructions for use for additional information
	ISO 15223-1: 2021 Reference no. 5.3.1. (ISO 7000-0621)	Medical devices — Symbols to be used with information to be supplied by the manufacturer - Part 1: General requirements.	Fragile, handle with care	Indicates a medical device that can be broken or damaged if not handled carefully
	IEC 60417-1 Reference no. ISO 7000-5016	Graphical symbols for use on equipment	Fuse	To identify fuse boxes or their location
	IEC-TR-60878 Reference no. ISO 7000-1135	Graphic symbols for use on electrical equipment in a medical practice	General symbol for recover/recyclable	To indicate that the marked item or its material is part of a recovery or recycling process
	ISO 15223-1:2021 Reference no. 5.5.1.	Medical devices — Symbols to be used with information to be supplied by the manufacturer - Part 1: General requirements.	In Vitro diagnostic medical device	Indicates a medical device that is intended to be used as an in vitro diagnostic medical device
	ISO 15223-1: 2021 Reference no. 5.3.2. (ISO 7000-0624)	Medical devices — Symbols to be used with information to be supplied by the manufacturer - Part 1: General requirements.	Keep away from sunlight	Indicates a medical device that needs protection from light sources
	ISO 15223-1: 2021 Reference no. 5.1.1. (ISO 7000-3082)	Medical devices — Symbols to be used with information to be supplied by the manufacturer - Part 1: General requirements.	Manufacturer	Indicates the medical device manufacturer
	DIRECTIVE 2012/19/EU (WEEE)	N/A	Collect separately	Separate collection for waste of electrical and electronic equipment. Do not dispose of battery in municipal waste. The symbol indicates separate collection for battery is required
	Directive 2002/96/EC (WEEE)	N/A	Collect separately	Separate collection for waste of electrical and electronic equipment. Do not dispose of battery in municipal waste. The symbol indicates separate collection for battery is required
	N/A	N/A	Open bottle stability	Indicates a reagent is stable after opening for the number of months specified
	ISO 15223-1: 2021 Reference no. 5.1.7. (ISO 7000-2498)	Medical devices — Symbols to be used with information to be supplied by the manufacturer - Part 1: General requirements.	Serial number	Indicates the manufacturer's serial number so that a specific medical device can be identified
	ISO 15223-1: 2021 Reference no. 5.3.7. (ISO 7000-0632)	Medical devices — Symbols to be used with information to be supplied by the manufacturer - Part 1: General requirements.	Temperature limit	Indicates the temperature limits to which the medical device can be safely exposed
	ISO 15223-1: 2021 Reference no. 5.1.4. (ISO 7000-2607)	Medical devices — Symbols to be used with information to be supplied by the manufacturer - Part 1: General requirements.	Use by date	Indicates the date after which the medical device is not to be used
	iso_grs_7010_WOO1	Medical devices — Symbols to be used with information to be supplied by the manufacturer - Part 1: General requirements.	General warning sign	To signify a general warning
	GHS02	Globally Harmonized System of Classification and Labeling of Chemicals (GHS), Eighth Revised Edition	flammable	Medical device contains materials that are flammable. Appropriate caution should be taken

SYMBOL	STANDARD REFERENCE	STANDARD TITLE	SYMBOL TITLE	SYMBOL MEANING
	GHS03	Globally Harmonized System of Classification and Labeling of Chemicals (GHS), Eighth Revised Edition	Oxidizing	Medical device contains materials that are oxidizing. Appropriate caution should be taken
	GHS05	Globally Harmonized System of Classification and Labeling of Chemicals (GHS), Eighth Revised Edition	Corrosive	Medical device contains materials that are corrosive. Appropriate caution should be taken
	GHS06	Globally Harmonized System of Classification and Labeling of Chemicals (GHS), Eighth Revised Edition	Toxic	Medical device contains materials that are toxic. Appropriate caution should be taken
	GHS07	Globally Harmonized System of Classification and Labeling of Chemicals (GHS), Eighth Revised Edition	Harmful	Medical device contains materials that are harmful. Appropriate caution should be taken
	GHS08	Globally Harmonized System of Classification and Labeling of Chemicals (GHS), Eighth Revised Edition	Health Hazard	Medical device contains materials that are a health hazard. Appropriate caution should be taken
	GHS09	Globally Harmonized System of Classification and Labeling of Chemicals (GHS), Eighth Revised Edition	Environmental Hazard	Medical device contains materials that are an environmental hazard. Appropriate caution should be taken
	N/A	Administrative Measure on the Control of Pollution Caused by Electronic Information Products (China)	Environment Friendly Use Period	Indicates the period of time before any RoHS substances are likely to leak out causing harm to the environment.
	N/A	N/A	Do not use pumps	Indicates products are to be used for manual cleaning only. Do not pump the product through instrument.
	ISO 15223-1: 2021 Reference no. 5.1.6. (ISO 7000-2493)	Medical devices — Symbols to be used with information to be supplied by the manufacturer - Part 1: General requirements.	Catalogue number Catalog number	Indicates the manufacturer's catalog number so that the medical device can be identified ISO 15223 Catalogue number ISO 7000 Catalog number
	ISO 15223-1: 2021 Reference no. 5.3.8. (ISO 7000-2620)	Medical devices — Symbols to be used with information to be supplied by the manufacturer - Part 1: General requirements.	Humidity limitation	Indicates the range of humidity t which the medical device can be safely exposed
	N/A	https://www.gov.uk/guidance/using-the-ukca-marking#when-to-use-the-ukca-marking	UKCA Mark	UK product marking that is required for medical devices being placed on the marketing in Great Britain.

SECTION 1
INTRODUCTION
1.2 Instrument Description

Figure 1: Front and Right Side Panels

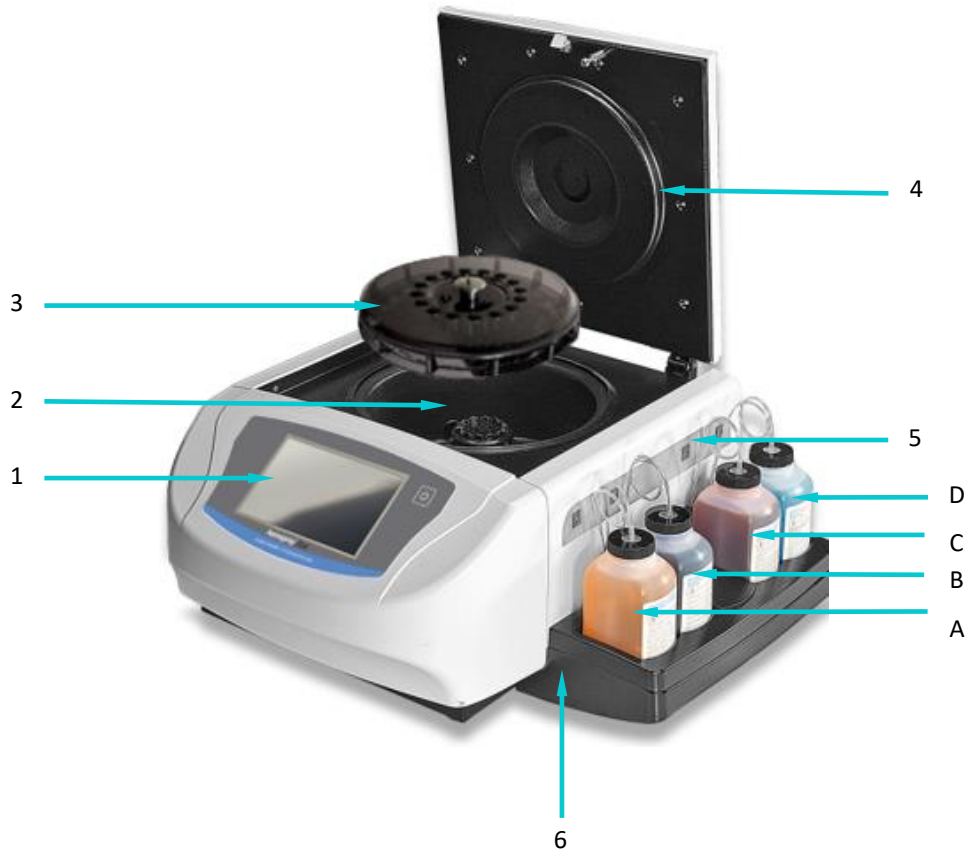

- 1 – Front Panel with touchscreen display
- 2 – Bowl
- 3 – Carousel
- 4 – Lid with safety lock
- 5 – Right Side Panel with label indicating reagent positions:
 - A – Rinse
 - B – Thiazin
 - C – Eosin
 - D – Methanol or Aerofix
- 6 – Reagent Tray

SECTION 1
INTRODUCTION

1.2 Instrument Description

Figure 2: Front Panel and Touchscreen



- 1 – Standby/Ready button
- 2 – Touchscreen

The front panel features an interactive touchscreen display. Refer to Table 8: Front Panel/Main Screen Function Keys later in this section for more information.

Figure 3: Rear Panel

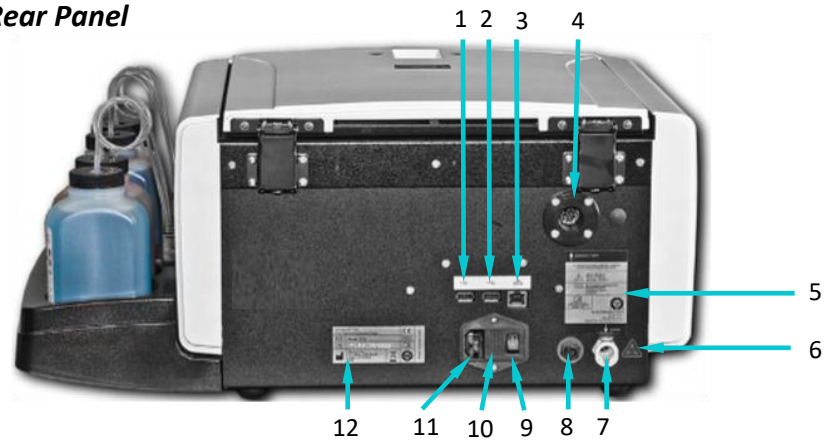

- 1 – Barcode scanner USB port
- 2 – Log export USB port
- 3 – Network ethernet connection (disabled)
- 4 – Exhaust vent
- 5 – Rear panel label
- 6 – Biohazard warning label
- 7 –Waste tube connection
- 8 – Level detect connection for waste container
- 9 – Power switch
- 10 – Fuse door
- 11 – Power cord connection
- 12 – Model/serial number label

1.2 Instrument Description

Figure 4: Stainer Bowl Components

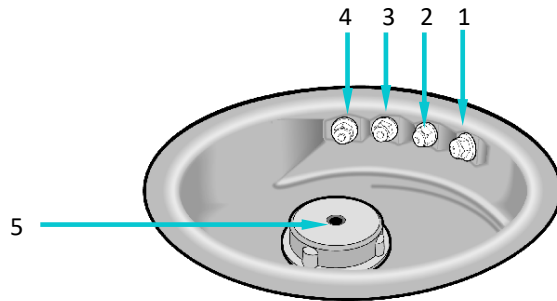

- 1 – Nozzle A (rinse)
- 2 – Nozzle B (thiazin stain)
- 3 – Nozzle C (eosin stain)
- 4 – Nozzle D (methanol or Aerofix)
- 5 – Drive hub



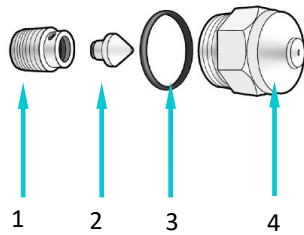





Figure 5: Nozzle Diagram



- 1 – Compression screw
- 2 – Swirl cone
- 3 – O-ring
- 4 – Nozzle housing

SECTION 1
 INTRODUCTION
1.2 Instrument Description

Table 7: Preventive Maintenance Kit

Component	Name	Description
	Manual Priming Tool	Primes air-locked pumps.
	Silicon Grease	Lubricates the nozzle threads for easy assembly.
	Nozzle Wire	Cleans nozzle housing orifices.
	Nozzle Cleaning Strainer	Strains the nozzle parts to prevent them from going down a drain.
	Nozzle Tool	Unscrews nozzles from the stainer bowl.
	Nozzle Hex Wrench	Disassembles the nozzle.
	Nozzle Brush	Assists in cleaning bowl and nozzle exterior.
	Volume Test Collection Tubes (small tube)	Collects reagents while performing the Volume Test.

SECTION 1
INTRODUCTION

1.2 Instrument Description

Table 7: Preventive Maintenance Kit (continued)

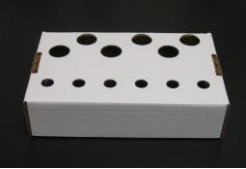
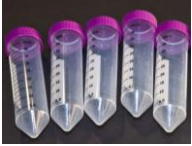











Component	Name	Description
	Nozzle Maintenance Tube Stand	Holds Nozzle Cleaning Tubes (large tube) and Volume Test Tubes (small tube).
	Nozzle Cleaning Tubes (large tube)	For soaking nozzles in the Nozzle Cleaning Solution.

SECTION 1
INTRODUCTION

1.3 Touchscreen and User Interface







Users control all instrument functions from the interactive touchscreen display.

Table 8: Front Panel/Main Screen Function Keys

Button	Name	Description
	Standby/Ready	With instrument power ON: Blue = Ready Amber = Standby Pressing Standby runs a System Clean cycle and places instrument into standby mode. The Standby/Ready button also accesses the touchscreen calibration function. Refer to System Setup Menu (Section 3.1).
	Maintenance	Accesses features for verifying proper nozzle performance and places pumps in a testing sequence. Accesses the line priming, Pattern Test, Volume Test, and B-Line Flush functions.
	Clean	Performs the Clean cycle.
	Cytocentrifuge	Enters the Cytocentrifuge mode.
	System Information	Shows the system information, including serial number and software version. Allows access to the System Setup features. Refer to System Setup Menu (Section 3.1).
	Help	Opens the software Help file.
	Programs	Allows users to select or edit programs.
	Start/Load Slides	Starts a Stain or Cytocentrifuge cycle. Button is inactive until a program is created. Refer to Creating a Stain Program (Section 3.1). With Slide Tracking enabled, opens the Scan and Load Slides menu (Section 3.2).
	Number of Specimen Slides	Selects the number of specimen slides in the carousel. Users staining an odd number of specimen slides should press the next higher specimen slide number icon.
	Back	Returns to the previous menu.
	Stop	Aborts any operation.
	OK	Indicates completion of current task.
	System Setup	Allows users to modify the software settings. See System Setup Menu (Section 3.1).

1.3 Touchscreen and User Interface

Table 9: System Setup Keys

Button	Name	Description
	Stain Programs	Allows users to create, edit, and delete stain programs.
	Cytocentrifuge Programs	Allows users to create, edit, and delete cytocentrifuge programs.
	Reagents	Allows users to edit reagent information.
	Users	Allows users to create and change user accounts.
	QC/Maintenance Tracking	Enables slide tracking, preventive maintenance tracking, and reagent tracking.
	Level Detect	Allows users to manage the automatic reagent level detection system.
	Language	Allows users to change the display language.
	System Log	Allows users to control logging functions.
	Network Settings	Disabled.
	Beeper	Allows users to change audible alerts.
	Set Date/Time	Allows users to set the date and time.
	Restore Defaults	Restores programming to default settings.
	Login	Enters Login sequence for authorized users.
	Logout	Logs authorized users out. Users must log in again to use the stainer.

SECTION 1
INTRODUCTION

1.3 Touchscreen and User Interface

Table 9: System Setup Keys (continued)















Button	Name	Description
	Save	Saves the entered or selected information.
	Add	Enters programming mode for creating staining and cytocentrifuge programs. Also allows the system administrator to authorize new users. Allows manual entry of slide or specimen information.
	Delete/Erase/Remove	Deletes or erases the selected item.
	Edit/Change User	Allows editing of an existing stain or cytocentrifuge program. Allows manual entry of slide or specimen information (stain or cytocentrifuge mode). Also allows system administrator to edit user information.
	Zero	Zeros the Level Detect sensors.
	Calibrate	Calibrates the Level Detect system.
	Unselected	Shows an unselected option.
	Selected	Shows a selected or enabled option.

Table 10: Maintenance Function Keys

Button	Name	Description
	Individual Prime Buttons (A, B, C, D)	Primes the selected line.
	Pattern Test	Performs Pattern Test to ensure nozzles are clear of debris and spraying properly.
	Volume Test	Performs Volume Test to verify the selected nozzle volume is within the correct range.
	60-Sec Prime	Runs the pumps for 1 minute and primes the lines.
	QC/PM	Shows the Preventive Maintenance and Quality Control logs, when enabled from the System Setup menu (Section 3.1).
	Line Flush	Cleans the B and C reagent lines.
	ABCD Prime button	Primes all (A, B, C, D) reagent lines simultaneously.

SECTION 2 SETUP AND PREPARATION FOR OPERATION

2.1 Instrument Setup

Unpacking and Installing the Stainer

Follow this sequence for initial setup. Details about these operations are given in the next three sections.



CAUTION:

Contact Bruker Biomedical Systems before installing the instrument if you observe any damage to the packaging or equipment.

1. Unpack and inspect the instrument.
2. Check that the contents of the boxes match the packing lists for the instrument and accessories.
3. Open the instrument lid and remove the cardboard tube that protects the hub.

NOTE: *Keep the box and packaging material to repack the instrument if you intend to ship it to the manufacturer for service.*

4. Place the instrument on a flat surface, free from dust and vibration and away from direct sunlight.

NOTE: *Position the instrument with the rear panel at least 30 cm (12 in.) from obstructions or hazardous materials.*

SECTION 2 SETUP AND PREPARATION FOR OPERATION

2.1 Instrument Setup

Connecting the Drain Tube and Waste Container



1. Insert the waste tube connector into the rear panel receptacle until you hear a click.
2. Adjust the tube length to less than 1.8 m (72 in.).

NOTE: Ensure the waste tube has no loops or kinks and is as straight and as short as possible. Cut off excess tubing as needed.



3. Connect the drain tube to the waste container.

If using a waste bottle with level detect (AC-182):

4. Connect the waste monitoring cable to the rear panel receptacle.
5. Connect the waste monitoring cable to the waste container lid.

Connecting Power

1. Make sure the power switch is **OFF** (O).
2. Plug the power cord into the power connector on the rear panel of the instrument.

NOTE: Bruker recommends using a surge protector to isolate the instrument from electrical spikes and surges, which may damage the instrument.

3. Plug the power cord into a properly rated AC electrical outlet.
4. Turn the power switch **ON** (I). After a brief delay the Main menu will appear.



SECTION 2

SETUP AND PREPARATION FOR OPERATION

2.1 Instrument Setup

Installing Reagent Bottles

 **WARNING!**

Reagents used in the instrument contain moderately hazardous chemicals that require care in handling. Always handle reagents using appropriate safety measures, including gloves and eye protection.

 **CAUTION:**

Use only Bruker reagents, with diluents as specified for Bruker concentrated reagents. Reagents from other sources may contain organic solvents (such as ketones) or form precipitates, causing severe damage.



NOTE: Reagents should be stored according to the conditions specified on their label. After opening, reagents are stable for 90 days unless otherwise indicated by the symbol shown at left.

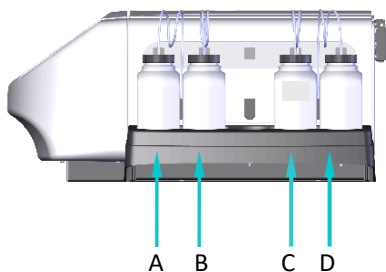

1. Place each 500 mL reagent bottle in the correct position.
 - (A) Rinse
 - (B) Thiazin Stain
 - (C) Eosin Stain
 - (D) Methanol

NOTE: See Appendix A for complete identification of all reagents used in this stainer.

NOTE: Immediately remove spills in the reagent tray to preserve the accuracy of the reagent level detecting system.

2. For all reagents:
 - Open a new bottle of reagent.
 - Remove the orange caps from the ends of the dip tubes.
 - Insert the corresponding dip tube into the reagent bottle and install the ring cap.

Installing the Optional Barcode Reader

An optional barcode reader (AC-181) can be connected to the stainer for scanning reagent bottles and specimen slides that contain barcodes. This allows easy reagent and specimen information tracking. If a barcode reader is not installed, reagent and specimen information can be entered manually (see Section 3.2).

1. Place the barcode reader and stand on a level surface near the stainer.
2. Plug the barcode reader into the left USB port on the rear panel of the stainer. See Section 3.2 for instructions on using the barcode reader.

SECTION 2 SETUP AND PREPARATION FOR OPERATION

2.2 Preparing the Stainer for Operation

Priming Procedures

NOTE: The instrument is shipped with alcohol in the reagent lines. For proper performance, this alcohol must be replaced with the correct reagent for each reagent line prior to use.

Thoroughly purge and prime each reagent delivery line using the following instructions:



1. Remove each spray nozzle with the provided nozzle tool by turning counterclockwise.

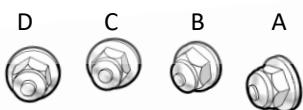

2. Note the location of each nozzle so you can return it to the original position during reassembly.



3. Place a carousel on the stainer hub to prevent stain from entering the motor shaft.

 **CAUTION:**

Fluid from priming can flood and damage the motor if the drain tube is not properly installed.



4. Press **Maintenance** from the Main menu.



5. Press the **A** prime button. Stain should appear within 10 seconds. When properly primed, a steady stream of reagent (no sputtering or breaks) flows from the nozzle receptacle.

- If stain appears, proceed to the next step.
- If stain does not appear within 10 seconds, perform the manual priming procedure (Section 6.3).



 **CAUTION:**

Never operate a dry pump for more than 10 seconds. Operating a dry pump may cause damage to the instrument.

6. Repeat the previous steps for each reagent line (B, C, and D). Close the lid when stain appears from all lines.

SECTION 2
SETUP AND PREPARATION FOR OPERATION

2.2 Preparing the Stainer for Operation

Priming Procedures (continued)

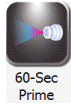

7. Press **60-Sec Prime** to prime each reagent line with reagent. This removes all of the alcohol from the reagent lines and pumps. Repeat this step to fully prime the system.



NOTE: To prime all lines at the same time, press **ABCD**. The pumps will run for 1 minute and prime all the lines. Follow instructions on the screen.



NOTE: To prime individual lines, press the appropriate individual prime button (A, B, C, D).

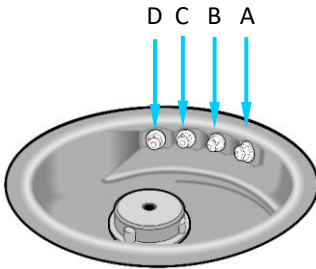

8. Return the nozzles to their original positions and tighten clockwise with the nozzle tool.

9. With the nozzles installed, repeat Steps 5 and 6. A fine cone of spray should come from each nozzle.

NOTE: If a fine cone of spray is not seen, refer to Section 6 for troubleshooting.

10. After verifying nozzle performance, a clean cycle must be performed before a stain cycle can be run.

SECTION 2

SETUP AND PREPARATION FOR OPERATION

2.2 Preparing the Stainer for Operation

The Clean Cycle

The clean cycle is a two-step process that cleans the reagent nozzles and the carousel. The first step purges each reagent line and cleans the empty carousel with methanol or Aerofix while cycle progress is displayed on the screen. The second step, which can be delayed indefinitely, reprimed the reagent lines with staining reagents.

NOTE: Pressing Standby/Ready performs a clean cycle before the instrument goes on standby.

1. Place an empty carousel in the instrument and close the lid.



CAUTION:

Never place any carousel loaded with specimens in the instrument for a clean cycle (including placing the instrument in standby mode). Specimens will be damaged if they contact reagents sprayed from the nozzles when you press Clean or Standby.



2. Press **Clean**.



NOTE: Pressing Stop during the clean cycle causes the Clean Cycle Cancelled message to be displayed. Press Clean to complete the interrupted cycle.

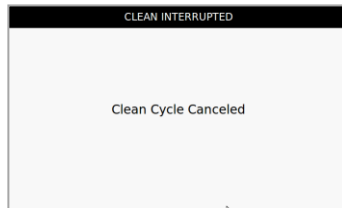

3. Press **Reprime** to reprime the lines.



4. Open the lid and remove the carousel when the clean cycle is complete.
5. Spray the interior of the bowl with 70 to 100% methanol or ethanol. Wipe the stainer bowl dry with paper towels.

NOTE: Perform the clean cycle if the instrument will remain idle for more than four hours.

Performing Tests

Bruker recommends performing the Pattern Test and Volume Test before using the stainer (see Section 6).

SECTION 2 SETUP AND PREPARATION FOR OPERATION

2.2 Preparing the Stainer for Operation



Reagent Level Monitoring

Reagent Level Detect monitors reagent levels and alerts you when the reagent is running low, or when the waste container is full (when using the waste container with level detect (AC-182)). You can turn reagent and waste container monitoring ON or OFF from the Level Detect menu. The system default is ON for reagent monitoring and OFF for waste container monitoring.

Table 11: Reagent Level Detect Display Symbols

Symbol	Description
	Reagent unselected in Level Detect
	Reagent bottle full
	Reagent bottle 2/3 full
	Reagent bottle 1/3 full
	Reagent bottle empty
	Measurement error (internal level detect problem)
	Reagent has exceeded expiration date (enabled from QC Maintenance menu)
	Waste bottle empty
	Waste bottle error (such as external bottle unplugged)
	Waste bottle full

NOTE: The instrument must be installed on a flat, level surface for accurate reagent monitoring.

⚠ CAUTION:

This system is designed to warn you when the reagent level is getting low. The instrument will continue running through these warnings. Always monitor and replenish (if needed) the reagent before running a stain cycle.

SECTION 2 SETUP AND PREPARATION FOR OPERATION **2.2 Preparing the Stainer for Operation**

Enabling/Disabling Reagent Level Detect



1. Press **Information** from the Main menu.



2. Press **System Setup**.



3. Press **Level Detect**. The display shows the following:

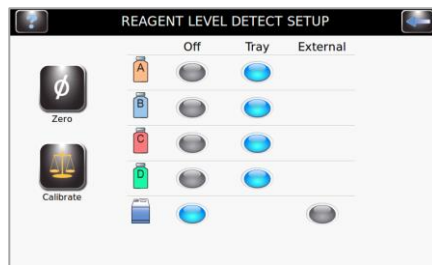

4. Press **Tray** to enable, or **Off** to disable a reagent line. Functions are gray when unselected and blue when selected. Press **External** to enable level detect for the waste bottle.



5. When finished, press **Back** to exit to System Setup menu.

SECTION 2
SETUP AND PREPARATION FOR OPERATION

2.2 Preparing the Stainer for Operation

Zeroing the Reagent Level Sensors

The Level Detect function must be zeroed at initial setup, when the stainer is moved, or if the level detect is not reporting correctly. If zeroing does not correct the problem, recalibrate the Level Detect function (Section 7.3).



1. Press **Information**.



2. Press **System Setup**.



3. Press **Level Detect** to enter the Reagent Level Detect Setup menu.

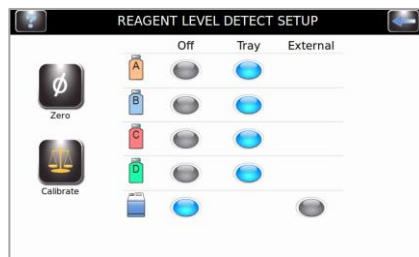

4. Press **Zero**. The display shows the following:

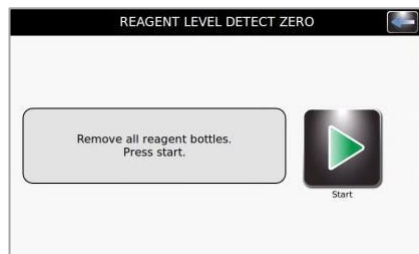

SECTION 2
SETUP AND PREPARATION FOR OPERATION
2.2 Preparing the Stainer for Operation

Zeroing the Reagent Level Sensors (continued)



5. Remove all reagent bottles and press **Start**.

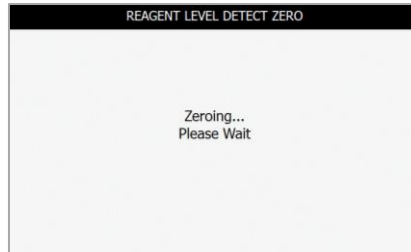

NOTE: Vibrations or bumps to the instrument or lab bench can cause inaccuracies in zeroing or calibration.



6. After zeroing, press **OK**. Press the **Back** button to exit to the System Setup menu.



7. Return the reagent bottles to their correct positions in the tray. It may take several seconds for the instrument to reflect the updated reagent status.

NOTE: For accurate reagent level detection and calibration, dip tubes must follow their preformed coiled shapes.

SECTION 3

CONTROLLING AND CUSTOMIZING STAINER FUNCTIONS

3.1 System Setup Menu

Many software settings can be controlled from the System Setup menu, including:

- Creating, editing, and deleting stain programs
- Creating, editing, and deleting cytoentrifuge programs
- Tracking reagent information
- Managing user accounts
- Enabling tracking features for slides, maintenance, and reagents
- Managing reagent level sensing
- Changing the display language
- Viewing and exporting the system log
- Changing beeper settings
- Setting the date and time
- Restoring default settings

Accessing the System Setup Menu



1. Press **System Information** from the Main menu.



2. Press **System Setup**. The following display shows:



Stain Programs

Stain Programs allow the user to create, edit, or erase staining programs according to the user's specific staining preferences. Up to 12 staining programs can be programmed and stored in memory.

Programmable staining parameters include stain intensity and fixation options:

- **Stain Intensity**
Selections range from 1 to 10. Setting 1 is the lightest and setting 10 the darkest. Settings 8, 9, and 10 are particularly appropriate for bone marrow specimens.
- **Fixation**
Fixation options are Off, Normal, and High.

SECTION 3

CONTROLLING AND CUSTOMIZING STAINER FUNCTIONS

3.1 System Setup Menu

Creating a Stain Program

1. From System Setup, press **Stain Programs**.

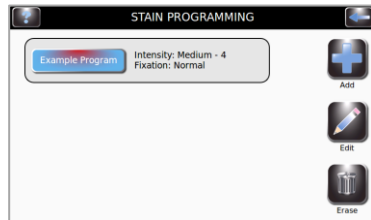

2. Press **Add**.

3. Select **Enter Program Name** and enter the desired name on the keypad.

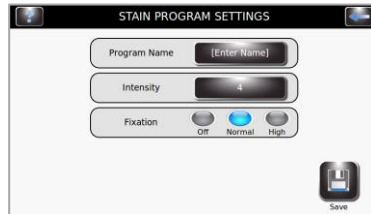

4. Press **Enter** on the keypad. The display returns to the Stain Programming Menu.

5. Press **Intensity** from the Stain Programming Menu. Select the desired stain intensity (1-10).

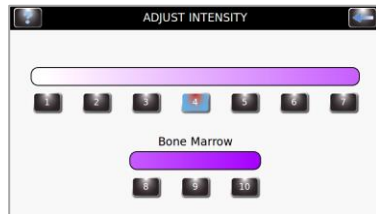

6. Select the desired Fixation (Off, Normal, High).



7. Press **Save**.

SECTION 3
CONTROLLING AND CUSTOMIZING STAINER FUNCTIONS
3.1 System Setup Menu

Editing, Renaming, or Adjusting Stain Programs

1. From the Stain Programs menu, select the program to be modified.

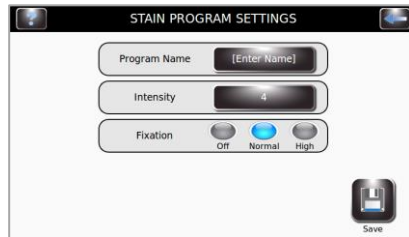

2. Press **Edit**.

3. Adjust the settings as needed.

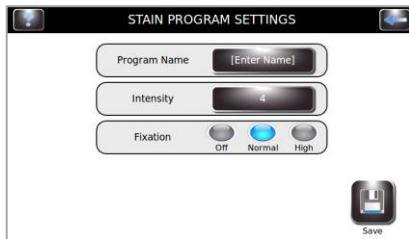

4. Press **Save**.

SECTION 3

CONTROLLING AND CUSTOMIZING STAINER FUNCTIONS

3.1 System Setup Menu

Administrator and User Accounts

You can create one Administrator account and multiple (up to 50) user accounts. The Administrator controls access to the system by adding and editing user accounts. Users cannot edit System Settings unless permitted by the Administrator.

Creating an Administrator Account



1. From System Setup, press **Users**.
2. Press **Lock System Setup Access**.

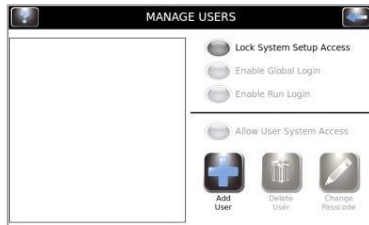

3. Enter a password for the Administrator account (at least 4 characters) and press **Enter**.



4. Re-enter the password and press **Enter** to confirm.

SECTION 3
CONTROLLING AND CUSTOMIZING STAINER FUNCTIONS
3.1 System Setup Menu

Creating User Accounts

Note: This function is available only if an administrator account has been created.



1. Press **System Setup**.
2. Enter the Administrator password.



3. Press **Enter**.



4. Press **Users** to reveal the Manage Users menu.

5. Press **Enable Global Login**.



6. Press **Add User**.
7. Enter a new user name. Press **Enter**.

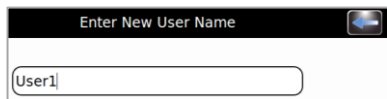

SECTION 3

CONTROLLING AND CUSTOMIZING STAINER FUNCTIONS

3.1 System Setup Menu

Creating User Accounts (continued)

8. Enter a numeric passcode (at least 4 numbers) for the user account. Press **Enter**.



9. Re-enter the passcode to confirm. Press **Enter**.



Managing User Access

From the Manage Users screen, the Administrator has several options to manage user access to the instrument.



- Enable Global Login allows users to log in to the instrument. Users will log out manually or automatically (with user-selectable time options). See User Login/Logout below.
- Enable Run Login requires the current user to enter a password to run a Stain or Cyto centrifuge cycle. Global Login must be enabled to use this option.
- User System Access enables complete control of the instrument, including changing the System Setup options. This option can be controlled on an individual user basis, if Global Login is enabled.

User Login/Logout

With System Access locked and Global Login enabled, users must log in to use the stainer:

1. Press **User ID** and **Select Logout** time after idling from the drop-down menu. Press **Login**.

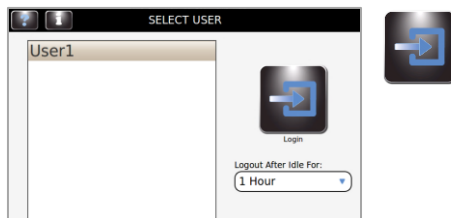

SECTION 3
CONTROLLING AND CUSTOMIZING STAINER FUNCTIONS
3.1 System Setup Menu

User Login/Logout (continued)

NOTE: Users can select how long the stainer can be idle before automatically logging the user out.

2. Enter the correct passcode for the selected user and press **Enter**.



3. The stainer returns to the Main menu and is ready for programming and staining. A Logout button and the username will appear at the top right of the Main screen.

NOTE: Users can log out manually by pressing the Logout button.

SECTION 3

CONTROLLING AND CUSTOMIZING STAINER FUNCTIONS

3.1 System Setup Menu

Using Reagent Information Tracking

You can enter reagent information to help track reagent usage and expiration. Reagent information includes reference number, expiration date, lot number, date and time the reagent was last installed.



1. From System Setup, press **QC/Maintenance Tracking**.
2. Select **Enable Reagent Tracking** by choosing reagent A, B, C, or D. This enables reagent lot number and expiration date tracking.
3. Press **Back** to return to System Setup.
4. Press **Reagents**.
5. Press **Change** next to the appropriate reagent.
6. Scan the reagent bottle barcodes (see Section 3.2) or manually enter the reagent information in the correct fields.
7. Press **Save** for each reagent. Repeat steps 5 to 7 for each reagent.

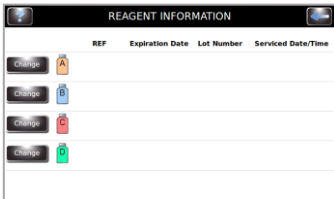

NOTE: See “Exporting Logs” later in this section for exporting log information.

Modifying Level Detect Functions

The Level Detect function alerts you when the reagent is running low, or when the waste container is almost full. You can turn reagent and waste container monitoring ON and OFF from the System Setup screen. The system defaults to ON for reagent monitoring and to OFF for waste container monitoring. See Section 2.2 for complete instructions.



1. From System Setup, press **Level Detect**.
2. Select the reagent monitoring options to be modified.
 - To disable monitoring, press **OFF** next to the appropriate reagents.
 - To enable monitoring, press **Tray** next to the appropriate reagents.
 - To monitor the waste container, press **External**.

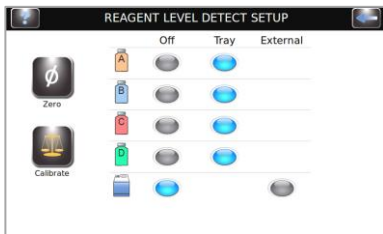

SECTION 3
CONTROLLING AND CUSTOMIZING STAINER FUNCTIONS
3.1 System Setup Menu

Changing User Language



1. From System Setup, press **Language**.
2. Select the software language from the list on the left.



3. Press **OK**.

Setting the Date and Time



1. From System Setup, press **Set Date/Time**.
2. Select **12** for a 12-hour clock or **24** for a 24-hour clock.
3. Use the up and down arrows to modify the time and date.



4. Press **Save**.

System Log

The instrument records all login, logout, stain or cytocentrifuge cycles, setting changes, maintenance functions and specimen identification (if enabled). These records can be accessed and exported by selecting the System Log icon (see left).

Accessing Logs



1. From System Setup, press **System Log**.
2. Use navigation arrows to scroll through the log.

Date/Time	User	Type	Status	Information
2013-09-12 11:42:23		Reagent	Serviced	A: Svc 12-Sep-2013 11:41
2013-09-12 11:41:33		Slide Tracking	Setting	Stain Slide Tracking Enabled
2013-09-12 11:41:22		System		System Settings Accessed
2013-09-12 11:41:09		System	Power On	
2013-09-12 11:41:05	Admin	Defaults	Loaded	System
2013-09-12 11:41:00	Admin	Login		System Settings Accessed
2013-09-12 11:40:02	User1	Login		1 Hour
2013-09-12 11:39:20	Admin	Logout		Manual

Navigation: Week 37, 2013 | Export

SECTION 3

CONTROLLING AND CUSTOMIZING STAINER FUNCTIONS

3.1 System Setup Menu

System Log (continued)

Exporting Logs



1. From System Setup, press **System Log**.



2. Plug a flash drive into the USB port on the right side.

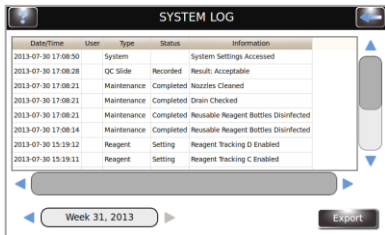

3. Press **Export**.

NOTE: The log files are exported to the flash drive as a CSV file that can be used in spreadsheet software programs.

Controlling Beeper Alerts



1. From System Setup, press **Beeper**.

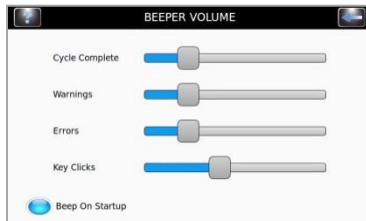

2. Use the sliders to modify the beeper volume for Cycle Complete, Warnings, Errors, or Key Clicks.
3. Press **Beep On Startup** to turn the audible startup alert ON or OFF.

QC/Maintenance Tracking

Under system default settings, the following QC/Maintenance Tracking options are disabled:

- Stain Slide Tracking
- Cyto Slide Tracking
- Manual Entry
- Preventive Maintenance Tracking
- Reagent Tracking

SECTION 3 CONTROLLING AND CUSTOMIZING STAINER FUNCTIONS

3.1 System Setup Menu

Enable Stain Slide Tracking

To activate Stain Slide Tracking:



1. From System Setup, Press **QC/Maintenance Tracking**.
2. Press **Enable Stain Slide Tracking**.

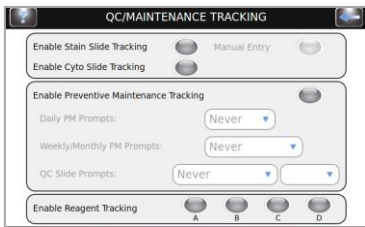

3. Press **Back** twice to return to the main screen. Verify that the Start Button on the main screen reads “Load Slides.”

NOTE: Selecting *Enable Stain Slide Tracking* changes the Start button on the Main menu to “Load Slides.”



4. Press **Load Slides**. The Scan and Load Slides menu appears.

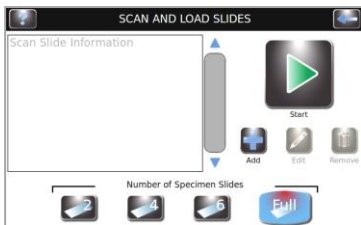

5. Enter slide information.
 - a. If using the barcode reader, scan the specimen slides that contain barcodes. See *Scanning Slides with the Barcode Reader* (Section 3.2).
 - b. If entering specimen information manually, see *Manually Entering Specimen Information* (Section 3.2).
6. See Section 4 for remaining steps for running a stain cycle.

NOTE: See “Exporting Logs” in this section for exporting log information.

NOTE: See Section 3.2 for complete process on recording specimen and reagent information.

SECTION 3 CONTROLLING AND CUSTOMIZING STAINER FUNCTIONS

3.1 System Setup Menu



Enable Cyto Slide Tracking

Allows slide tracking in cytocentrifuge mode. See the Cytopro Rotor Applications Manual (Aerospray Models 7xx2) (REF: RP-517) for complete information.

Enable Manual Entry

If selected, allows manual entry of slide information using the keypad (limited to 24 characters).

Enable Preventive Maintenance Tracking

To activate the tracking prompts for Preventive Maintenance Tracking, use the following steps:



1. From System Setup, press **QC/Maintenance Tracking**.

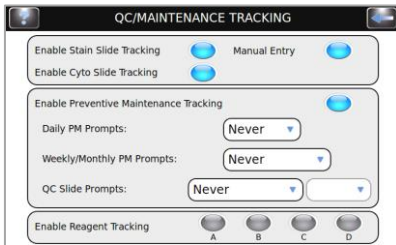

2. Press **Enable Preventive Maintenance Tracking**.

3. Enter the information for the Daily, Weekly, and QC Slide prompts in corresponding fields. Instructions for using the Preventive Maintenance Log are detailed in Section 5.1.

Enable Reagent Tracking

To activate Reagent Tracking:



1. From the **QC/Maintenance Tracking** menu, select the reagent (A, B, C, D) to be tracked.
2. Select **Enable Reagent Tracking**.
3. Select the reagent (A, B, C, or D) to be tracked.

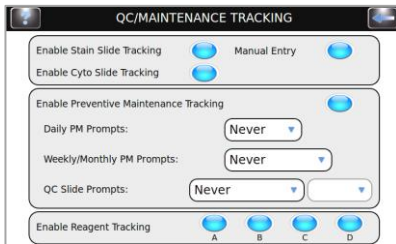

NOTE: See "Exporting Logs" in this section for exporting log information.

NOTE: See Section 3.2 for complete process on recording specimen and reagent information.

SECTION 3 CONTROLLING AND CUSTOMIZING STAINER FUNCTIONS

3.1 System Setup Menu

Restoring Software Defaults



1. From System Setup, select **Restore Defaults**.



CAUTION:

Restoring the system defaults will remove all personal settings.

- Restoring System Settings will delete all user names and passwords.
 - Restoring Stain Settings will delete all stain programs and restore the default programs.
 - Restoring Cytocentrifuge Settings will delete all cytocentrifuge programs and restore the default programs.
2. Select the settings you would like to restore to factory defaults: System Settings, Stain Settings, or Cytocentrifuge Settings.



3. Press **Restore**.



4. The display returns to the Main menu.

SECTION 3 CONTROLLING AND CUSTOMIZING STAINER FUNCTIONS

3.2 Recording Specimen and Reagent Information

Scanning Slides with the Barcode Reader



1. From System Setup select **QC/Maintenance Tracking**.
2. Select **Enable Stain Slide Tracking**.

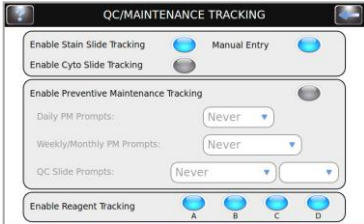

NOTE: Selecting *Enable Stain Slide Tracking* changes the *Start* button on the *Main* menu to “*Load Slides*.”



3. Press **Back** twice to return to the Main menu.



4. Press **Load Slides** on the Main menu. The Scan and Load Slides menu will appear.

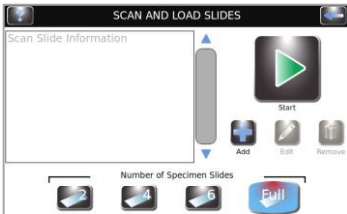

5. Scan the barcode of each slide in the batch and load into the carousel according to instructions in Section 4.1.



6. Verify that each barcode appears on the Scan and Load Slides menu.

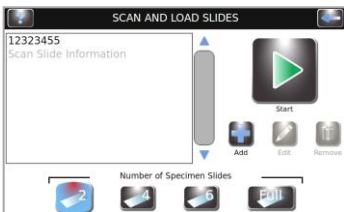

7. When you have completed preparations to stain (Section 4.1), press **Start**.



SECTION 3

CONTROLLING AND CUSTOMIZING STAINER FUNCTIONS

3.2 Recording Specimen and Reagent Information

Scanning Reagent Bottles with the Barcode Reader



1. From System Setup select **QC/Maintenance Tracking**.

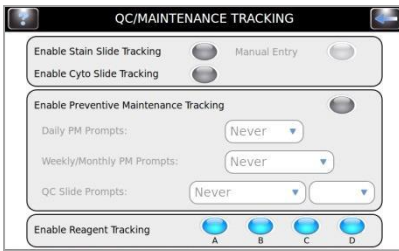

2. Select **Enable Reagent Tracking** for each desired reagent (A, B, C, D).



3. Press **Back** to return to the System Setup menu.



4. Press **Reagents** to reveal the Reagent Information screen.

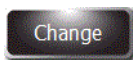
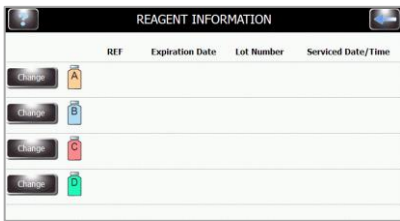

5. Select the desired Reagent (A, B, C, D) and press **Change**.



6. Scan the barcode of each enabled reagent bottle.

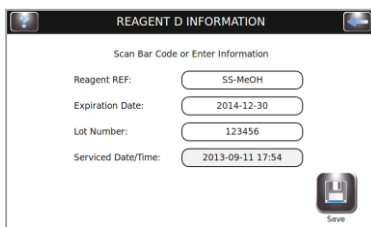

7. Verify that the barcode appears on the Scan and Load Slides menu.

SECTION 3

CONTROLLING AND CUSTOMIZING STAINER FUNCTIONS

3.2 Recording Specimen and Reagent Information

Scanning Reagent Bottles with the Barcode Reader (continued)



8. Press **Save**.



9. Repeat steps 3-8 for each reagent bottle that is enabled in QC Maintenance Tracking.

NOTE: You can access Reagent Information by pressing the bottle icons on the right side of the Main menu. This takes you directly to the Reagent Information menu, where you can scan or manually enter reagent information by pressing **Change**.

Manually Entering Specimen Information

With Stain Slide Tracking and Manual Entry enabled in the QC Maintenance menu:



1. Press **Load Slides** on the Main menu.



2. Press **Add** to reveal the keypad.



3. Enter slide information (maximum of 24 characters) and press **Enter**.



4. To change or delete the entry, select the entry on the display and press **Edit** or **Remove**.



5. Load slides and run stain cycle as shown in Section 4.1.

NOTE: Reagent REF number must be a valid Bruker REF number for the selected reagent. Incorrect entries will generate an error message.

SECTION 3

CONTROLLING AND CUSTOMIZING STAINER FUNCTIONS
3.2 Recording Specimen and Reagent Information

Manually Entering Reagent Information



1. Press **Reagents** from the System Setup menu or press the reagent status icon on the Main menu to reveal the Reagent Information menu.



2. Select the desired reagent and press **Change**.

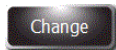
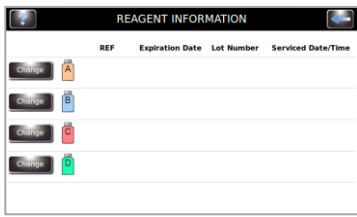

3. Select the desired field (Reagent REF, Expiration Date, Lot Number, or Service Date/Time).

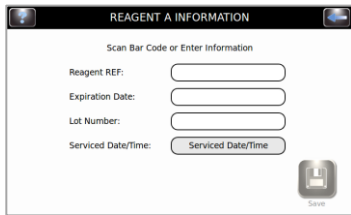

4. Enter the information on the keypad and Press **Enter**. Press **Save**.

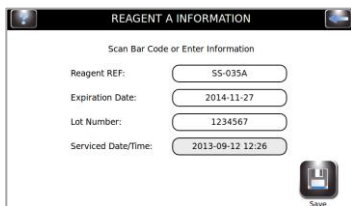

SECTION 3 CONTROLLING AND CUSTOMIZING STAINER FUNCTIONS

3.3 The Help Menu

The Help Menu is a comprehensive onscreen help function that provides detailed information about the active screen. See the screenshot below for an example.

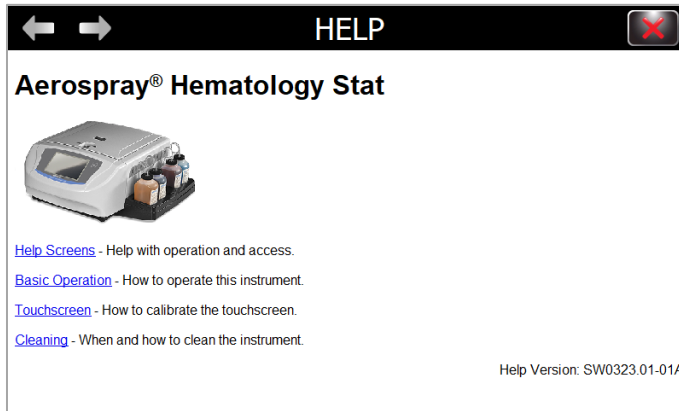

Using Help



1. Press **Help** to access the help function.

2. Select the desired topic.



3. Use the direction arrows to navigate.



4. Press **Exit** to return to the Main menu.

4.1 Operating Instructions



WARNING!

Treat slides in accordance with good laboratory practices and local regulations.

Suggested Staining Protocol

1. Verify that required maintenance has been performed.
2. Check reagent and waste levels.
3. If slide tracking is enabled, scan or enter slide information.
4. Load slides into the carousel. If the carousel is not full, use blocking slides (see “Using Blocking Slides” later in this section).
5. Place loaded carousel into the stainer and close the lid.
6. Select or verify desired stain program.
7. If slide tracking is not enabled, enter the number of slides on the Main menu.
8. Perform a stain cycle.
9. Unload the carousel.



Checking Reagent and Waste Levels

If enabled, the stainer displays the approximate reagent and waste container levels and other information.



Before each run, check the reagent and waste container levels on the display (if enabled) and by direct inspection of the bottles. The display will show the approximate level of each reagent.

Never allow a reagent to run dry. When the reagent level is near empty, replace the reagent bottle with a new one (see below). Do not put residual reagent from a used bottle into a new bottle. This can lead to an accumulation of residue on the slides and may be a source of contamination.

If reagent runs dry, you must re-prime the system using the instructions in Section 2.2.

Never allow the waste container level to go above the maximum safety level.



WARNING!

Reagents used in this instrument contain moderately hazardous chemicals that require care in handling. Always use appropriate safety measures, including gloves and eye protection, when handling reagents.

Replacing a Reagent Bottle

1. Remove the empty reagent bottle from the tray but do not disconnect the dip tube.
2. Open the new bottle and, if desired, record the letter on the cap for future use, such as long-term storage.

SECTION 4

OPERATING THE STAINER

4.1 Operating Instructions

Replacing a Reagent Bottle (continued)

3. Open the Reagent Information menu by pressing the reagent bottle icon on the right side of the Main menu.
4. Select the desired reagent and press **Change**.

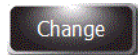

5. If you are using reagent tracking, scan the barcode or manually enter the reagent REF, expiration date and lot number in the Reagent Information menu (Section 3.2).
6. Unscrew the cap and remove the dip tube from the empty bottle.
7. Insert the dip tube into the new reagent bottle and screw on the cap.
8. Place the new bottle in the tray.



Emptying the Waste Container

The Level Detect function automatically monitors the waste level and indicates when the waste container should be emptied. It is still necessary to check waste levels visually to ensure the waste container does not overflow.



CAUTION:

Dispose of collected waste according to local statutes and safety requirements.

1. Unscrew the cap from the full waste container.
2. Discard the waste according to local regulations.
3. Reinstall the cap on the empty waste container.

Loading the Carousel



CAUTION:

Never load chipped or cracked slides into the instrument. Slides in poor condition may break during the staining cycle. If a slide breaks in the bowl, see Cleaning Broken Slides (Section 5.4).

SECTION 4 OPERATING THE STAINER

4.1 Operating Instructions



CAUTION:

Keep small ferrous metal objects away from the lab bench. These objects can be attracted to the magnets on the bottom of the carousel and cause damage if spun free during instrument operation.



CAUTION:

Load slides in balanced pairs. If staining an odd number of slides, use a blank slide to balance the carousel.

NOTE: The Hematology Stat Stainer automates the typical manual staining steps of the hematology workflow. In general, no special collection, pre-treatment, or storage conditions are required.

NOTE: Load the carousel with similar specimens for a similar level of staining. There is no guarantee of staining performance when dissimilar specimens are used.

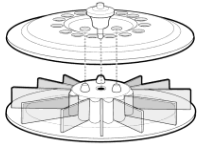

1. Remove the carousel from the bowl and place it on a solid, level surface.
2. Remove the carousel lid by pressing the button and lifting the lid.



3. If Slide Tracking is enabled, press **Load Slides**.
 - If using the barcode reader, scan each specimen slide barcode before loading it into the carousel. Slide Tracking must be enabled from the System Setup menu. See Enable Stain Slide Tracking (Section 3.1).
 - If entering slide information manually, follow the instructions in Section 3.2.
4. Insert the slides into the carousel with the first slide in position 1.
 - Load slides in balanced pairs (directly opposite one another) to balance the carousel. If staining an odd number of slides, use a blank slide to balance the carousel.
 - If the carousel is not full, use blocking slides (see below).
 - Load slides with the labels toward the outside edge of the carousel.
 - Always load slides with the specimen facing clockwise.
 - Always place the first slide in position 1, the second in position 2, and so on.



NOTE: A warning will sound during the staining cycle if the carousel is unbalanced.

SECTION 4
OPERATING THE STAINER
4.1 Operating Instructions

Figure 6: Specimen Placement on Slide

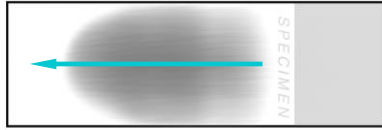

NOTE: For best results, place smear with the feathered edge toward the other edge of the carousel.

Figure 7: Loading the Carousel

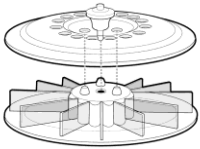
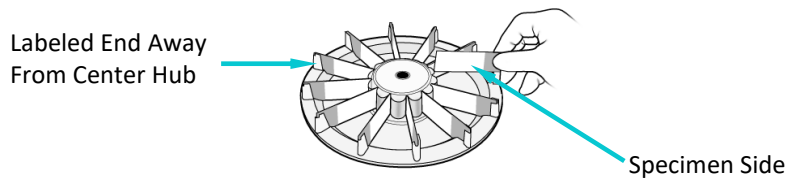

5. Replace the carousel lid by pressing the button and lowering the lid over the indexing posts.
6. Release the button and press the lid handle until it is firmly closed and locked.

SECTION 4
OPERATING THE STAINER
4.1 Operating Instructions

Using Blocking Slides

If the carousel is not full, blank slides should be used as blocking slides. Blocking slides prevent overspray of reagents onto the specimen slides. Overspray can cause slides to become over-stained.

Place a blocking slide in front of positions 1 and 2 shown in Figure 9 (positions 11 and 12).

Figure 8: Using Blocking Slides

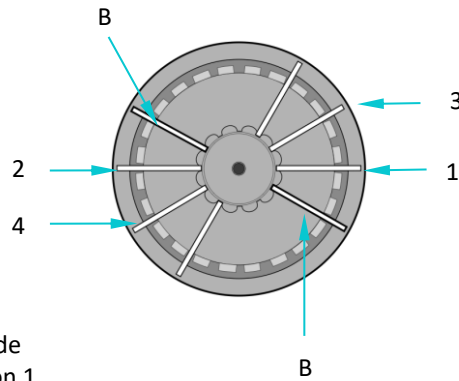

- B – Blocking Slide
- 1 – Slide Position 1
- 2 – Slide Position 2
- 3 – Slide Position 3
- 4 – Slide Position 4

Performing a Stain Cycle



1. Insert a carousel loaded with specimen slides and close the instrument lid.
2. If you have not enabled Slide Tracking, select the number of slides to be stained. Slide selection defaults to full carousel at the end of the run, after pressing Stop, or selecting a number greater than the full carousel default.

NOTE: If your exact number of slides is not shown, select the next highest number shown on the display. For example: to stain 3 slides, select 4, etc. Do not include blocking slides in the total number of slides.



NOTE: If entering slide information by barcode reader or keypad, the number of slides is programmed automatically. Adjust the total number of slides if adding other specimen slides that have not been entered by barcode reader or keypad.

SECTION 4

OPERATING THE STAINER

4.1 Operating Instructions

Performing a Stain Cycle (continued)

3. If you have created a stain program and it appears on the display, proceed to Step 4. If the desired program does not appear on the display, press **Programs**. Then select the desired program and proceed to Step 4.

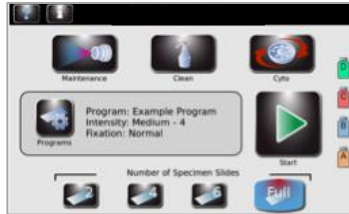

4. Press **Start**. The display shows the progress of the program, and a signal tone (if enabled) indicates the end of the cycle.

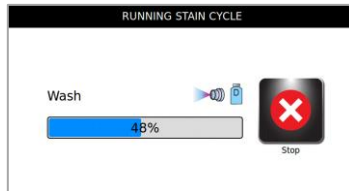

NOTE: Use the emergency Stop button when required, for example, if there is abnormal vibration or noise. This will abort the staining cycle.

Unloading the Carousel



WARNING!

Treat slides in accordance with good laboratory practices and local regulations.

1. Remove the carousel from the bowl and place it on a solid, level surface.

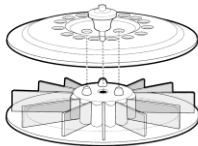

2. Remove the carousel lid by pressing the button and lifting the lid.
3. Carefully remove each slide.

SECTION 5

PREVENTIVE MAINTENANCE AND SAFETY

5.1 Preventive Maintenance

The frequencies set forth for maintenance are the *minimum* required. Field conditions and usage may require additional maintenance. This preventive maintenance is designed to keep nozzle performance within specification and slides staining correctly. If nozzle performance or stained QC slides are not as expected, increase the frequency of maintenance.

The system provides a Preventive Maintenance Log for tracking the most recent maintenance activities. See Enable Preventive Maintenance Tracking (Section 3.1) and Using the Preventive Maintenance Log in this section. Preventive Maintenance Chart (SS-265) may also be used.

Daily Maintenance/Quality Control (QC)

1. Check reagent levels and expiration dates.
 2. Empty the waste container if necessary.
 3. At the beginning of the day:
 - Wipe down the exterior of the instrument with 70 to 100% alcohol.
 - Perform a Hub Pattern test.
 - Run a QC slide if required by your laboratory.
- NOTE:** If staining will not be performed immediately, run a clean cycle (see Section 2.2) after the Hub Pattern test.*
4. At the end of the day, end of each shift, or if the instrument will be idle for more than four hours:
 - Place an empty carousel in the bowl and close the lid. Press **Standby/Ready** on the front panel and wait until the end of the automatic cleaning process, or press **Clean**.
 - Spray and wipe the bowl, interior lid, and nozzles with 70 to 100% alcohol.
 - A nozzle brush is provided in the Maintenance Kit to assist in this process.
 5. Ensure the maintenance procedures listed on the Maintenance Log have been performed and entered into the chart or log.

Weekly Maintenance

1. Wipe the carousel tray and lid using 70 to 100% alcohol.
2. Perform a Volume Test (Section 6.4).
3. Perform a Hub Pattern Test (Section 6.6).
4. Manually clean the nozzles, if necessary, based on the Volume and Hub Pattern Test results.
5. Wipe the carousel tray and lid using 70 to 100% alcohol.
6. Slowly pour 200-300 mL of water into instrument drain to prevent buildup of paper fibers, precipitates, etc. Verify the drain is flowing properly and not allowing fluid to back up in bowl or flow out of air vent on case back.
7. Ensure the maintenance procedures listed on the Maintenance Log have been performed and entered into the chart or log.

***NOTE:** If staining will not be performed immediately, run a clean cycle (see Section 2.2) to prevent concentrated reagent from sitting in the lines for extended periods of time.*

SECTION 5 PREVENTIVE MAINTENANCE AND SAFETY

5.1 Preventive Maintenance

Monthly Maintenance

1. Disassemble and manually clean all nozzles. Refer to Nozzle Disassembly and Cleaning (Section 6.1).
2. After cleaning nozzles, always perform a Volume Test (Section 6.4) and a Hub Pattern Test (Section 6.6).

NOTE: If staining will not be performed immediately, run a clean cycle (see Section 2.2) after Volume and Hub Pattern tests.

3. Disinfect any reagent bottle that has not been refilled within the last 90 days (Section 5.5), and/or upon visual inspection of the reagent for contamination.
4. Ensure the maintenance procedures in the Preventive Maintenance (PM) Log have been performed and entered into the PM chart or log.

Annual Maintenance

Although daily, weekly, and monthly maintenance procedures are set forth above, adding additional maintenance steps to be performed annually is not mandatory. However, field conditions and usage may warrant an optional annual overall check of the instrument's internal and external tubing and line flushes to ensure optimal staining performance.

Using the Preventive Maintenance Log

With Preventive Maintenance Tracking enabled, the PM Log provides a convenient and structured means of recording important maintenance and QC functions. The system allows you to set up timely prompts that require response by the user. See Enable Preventive Maintenance Tracking (Section 3.1).



1. From the Maintenance menu, press **QC/PM** to open the PM Log.

Hub Pattern		Nozzle Volume	
Date Completed	Result	Date Completed	Result (mL)
A:		A:	
B:		B:	
C:		C:	
D:		D:	

Maintenance		QC Slides	
Task	Date Completed	Date Completed	Result
Disinfect Bottles			
Drain Check			
Nozzle Cleaning			

Record Maintenance

2. Press **Record Maintenance**.

PM Task entry options:

- QC Slide Staining (Drop Down Menu)
 - Not Completed
 - Acceptable
 - Unacceptable
 - Inconclusive
- Disinfect Reusable Bottles
 - Completed (Select/Deselect)
- Drain Check
 - Completed (Select/Deselect)
- Manual Nozzle Cleaning
 - Completed (Select/Deselect)

SECTION 5
PREVENTIVE MAINTENANCE AND SAFETY
5.1 Preventive Maintenance

Using the Preventive Maintenance Log (continued)



3. Press **Save** to record entries.

5.2 Storing the Instrument

If the instrument is inactive for more than one week, you may want to perform the long-term storage procedure. This will prevent nozzles from clogging when the instrument is reactivated.

Preparing for Long-Term Storage

1. With the carousel removed, remove and clean the nozzles. Store parts in tubes filled with methanol that are labeled to indicate their correct position. These can be stored indefinitely.
2. Unscrew the cap and remove the dip tube from the bottles.
3. Place the end of the dip tube in a bottle of methanol.
4. Flush at least 250 mL of methanol through each reagent line by priming all lines (see section 2.2). Leave the methanol in the line.



CAUTION:

Leave methanol in the reagent lines during storage. Allowing reagent lines to run dry can damage the instrument.



CAUTION:

Do not subject the instrument to freezing temperatures. Freezing of aqueous fluids in the lines may cause damage to the instrument.

5. Flush the bowl with water.

Preparing for Operation after Storage

Follow the Setup and Preparation for Operation instructions (Section 2).

SECTION 5 PREVENTIVE MAINTENANCE AND SAFETY

5.3 Replacing Fuses



WARNING!

To prevent the risk of fire, the main fuses should only be replaced with fuses of the same type and rating. Recurring fuse failure indicates serious internal problems, if this occurs, contact the Bruker Biomedical Systems' Service Team.

1. Power off the instrument.
2. Disconnect the power cord from the power outlet and the rear panel of the instrument.
3. Open the fuse cover by inserting a screwdriver in the slot on the right side of the cover and gently prying the cover open.
4. Remove the fuse holders to inspect the fuses.
5. Replace the fuses if necessary.
6. Push the fuse holders in.
7. Close the fuse cover.
8. Reconnect the main power cord to the rear panel of the instrument and to the power outlet.
9. Power on the instrument.

SECTION 5
PREVENTIVE MAINTENANCE AND SAFETY
5.4 Cleaning the Stainer and Carousels



WARNING!

All cleaning procedures should be performed in a well-ventilated room by authorized and trained personnel wearing appropriate protection equipment.

1. Clean the outside of the instrument with 70 to 100% ethanol or methanol.
2. Clean the carousel and lid with 70 to 100% ethanol or methanol.

NOTE: Freshly prepared (< 24 hours old) 10% bleach solution can be used as well. The 10% bleach solution helps clean the stained areas.

Cleaning Liquid Spills

Remove any liquid spilled on the instrument immediately to avoid damage to the equipment.



WARNING!

If potentially infectious liquid is spilled on the instrument, the instrument must be disinfected in accordance with all applicable local regulations. Refer to Decontaminating the Stainer and Carousels (Section 5.5) for instructions.

Cleaning Broken Slides

You must take stringent precautions if a slide breaks inside the instrument during a staining cycle, especially if the instrument has been processing dangerous specimens. Always use protective gloves, safety glasses, and forceps when removing broken glass from inside the instrument.

- Glass shards embedded in the walls of the bowl can cause serious cuts and pose a risk of infection.
- Always remove embedded shards with a scraper before attempting to remove loose glass.
- Use a vacuum or adhesive tape to pick up loose glass inside the stainer bowl.

SECTION 5

PREVENTIVE MAINTENANCE AND SAFETY

5.5 Decontaminating the Stainer and Carousels

All parts of the instrument that come in contact with biological specimens, patient specimens, positive control specimens, or hazardous material must be treated as potentially infectious.

Before the instrument is returned for service, all outer surfaces must be decontaminated. The operating authority must complete a disinfection declaration, otherwise the instrument may be rejected by the distributor or service center or quarantined by customs authorities.

 **WARNING!**

Reagents used with the instrument contain moderately hazardous chemicals that require care in handling. Always use appropriate safety measures including gloves and eye protection, when handling reagents.

 **WARNING!**

Authorized and trained personnel wearing appropriate protection equipment should perform the decontamination procedure in a well-ventilated room. It is very important to thoroughly decontaminate the instrument before removing it from the laboratory or before performing any technical service. This procedure may not be effective against prions.

 **WARNING!**

Prior to decontaminating, disconnect the instrument from the main power supply to avoid any risk of fire or explosion.

 **WARNING!**

The decontamination procedure and the disinfectants must comply with the local applicable regulations.

Solutions for Decontaminating the Instrument

The outer surfaces of the instrument should be decontaminated using a decontaminating solution such as:

- 70% ethanol or methanol
- Mild detergent
- 10% bleach solution (< 24 hours old)
- Decontamination Solution (REF: SS-133)

Decontaminating the Instrument

1. Prepare a suitable container for all disposables.
2. Cover the lid locking mechanism and locking-pin holes with waterproof tape to protect the interior (Figure 9).

SECTION 5
PREVENTIVE MAINTENANCE AND SAFETY
5.5 Decontaminating the Stainer and Carousels

Figure 9: Lid Locking Mechanism and Pin Hole Locations



1 – Lid Locking Mechanism
2 – Locking Pin Hole

3. Decontaminate the stainer in a well-ventilated area. If ventilation is inadequate, perform the decontamination using a safety hood.
4. Spray the bowl and inner lid with a decontaminating solution such as REF: SS-133.
5. Repeat the spray treatment every 2-3 minutes for a total of 20 minutes. Do not allow cleaning solutions to dry on the instrument surfaces.
6. Rinse the bowl and lid thoroughly with water.
7. Spray and wipe the exterior surfaces with decontamination solution such as REF: SS-133.



CAUTION:

Do not flood the display panel with excessive moisture. Any moisture that seeps through could damage the internal electronics.

8. Repeat the spray treatment of exterior surfaces every 2-3 minutes for a total of 20 minutes. Do not allow cleaning/decontamination solutions to dry on the instrument surfaces.
9. Wipe surfaces thoroughly with a cloth soaked in water until you have removed all decontamination solution.
10. Immerse or generously spray the carousel and lid with decontaminating solution. Allow the solution to react for 20 minutes.
11. Thoroughly rinse the carousel and lid with deionized or distilled water.

SECTION 5 PREVENTIVE MAINTENANCE AND SAFETY

5.5 Decontaminating the Stainer and Carousels

Decontaminating Reagent Bottles

Any reused reagent bottles should be disinfected at each reagent lot change, or monthly:

1. Fill the reagent bottle with a fresh (< 24 hours old) 10% bleach solution.
2. Allow the bleach solution to react in the bottle for 10 minutes.
3. Rinse the bottle thoroughly with tap water.
4. Rinse the bottle thoroughly with deionized or distilled water.

5.6 Shipping or Disposing of the Stainer or Carousels

Shipping the Instrument or Carousels



WARNING!

You must disinfect the instrument or carousels before returning it to Bruker Biomedical Systems. The operating authority must complete a Hazard-Free Certification form, otherwise the distributor or service center may not accept the instrument; or customs authorities may hold it.



CAUTION:

Shipping the instrument or carousels without decontaminating according to these instructions is dangerous to service personnel. You will be charged additional fees for decontamination performed by Bruker Biomedical Systems.



CAUTION:

Ship the instrument or carousels in containers comparable to the original packaging.



CAUTION:

Always ship the instrument with methanol in the lines. Freezing during shipment with water in the Reagent A line, for example, can cause damage to the instrument.

Hazard-Free Certification

The Hazard-Free Certification (obtained from Bruker Biomedical Systems' Customer Service) must be included.

Disposing of the Instrument or Carousels

The instrument and carousels should be completely decontaminated and disposed of as follows:



Under WEEE Directive 2012/19/EU, this equipment cannot be disposed of in a municipal landfill. Instead, the equipment must be disposed of either by:

1. Routing to an authorized local facility approved for handling hazardous materials.

OR

2. Returning the equipment to Bruker Biomedical Systems or an authorized distributor.

SECTION 6

NOZZLE MAINTENANCE AND PERFORMANCE

6.1 Nozzle Disassembly and Cleaning

Nozzle maintenance requires the Nozzle Maintenance Kit and either methanol or prepared Nozzle Cleaning Solution (diluted REF: SS-029C).



WARNING!

Always wear protective clothing and eye protection when using Nozzle Cleaning Solution (SS-029 or diluted SS-029C). Dispose of used solution properly.

NOTE: Do not mix or interchange nozzles or nozzle parts. Always return nozzles to same location in stainer.

Nozzle Disassembly

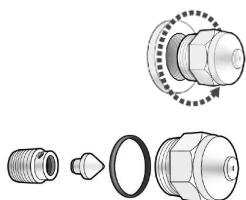

1. Remove the nozzle using the nozzle tool from the Nozzle Maintenance Kit.
2. Disassemble the nozzle by inserting and twisting the nozzle hex wrench into the compression screw to remove the nozzle housing.

NOTE: If the compression screw cannot be easily loosened, use light penetrating oil and a 5/8-in. wrench to loosen the nozzle.

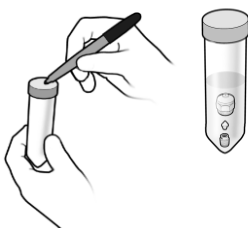

3. Place the nozzle parts (minus the o-ring if required) in a 50 mL conical tube that has been clearly marked with the correct nozzle position.

NOTE: If you will be storing the nozzle parts in Nozzle Cleaning solution longer than one hour, remove the o-ring. This is not required if using methanol.

4. Repeat Steps 1 through 3 for each nozzle.

Nozzle Cleaning



1. Add either methanol or prepared Nozzle Cleaning Solution (SS-029C) to each conical tube to fully immerse the nozzle parts and cap the tube.
2. Gently invert the tube at least ten times.
3. Soak the nozzle parts for at least five minutes. Parts can be soaked in nozzle cleaning solution overnight. If using methanol, parts can be stored up to 60 days.
4. Repeat steps 1 through 3 for each nozzle.

SECTION 6

NOZZLE MAINTENANCE AND PERFORMANCE

6.2 Nozzle Reassembly

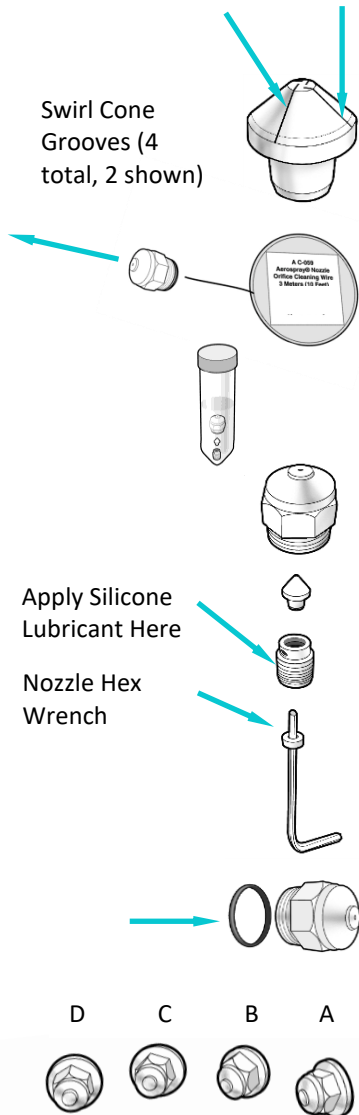

1. Hold your thumb or a nozzle strainer over the end of the tube to keep the nozzle parts in the tube. Discard the cleaning solution according to applicable statutes.
2. Inspect the nozzle parts. Remove any material in the swirl cone grooves by sliding a piece of paper edgewise along each of the 4 grooves.
3. Thread the nozzle orifice cleaning wire (REF: AC-059) through the disassembled nozzle housing.
4. Rinse the parts again with alcohol.
5. Reassemble the nozzle by placing the compression screw on the nozzle hex wrench, then inserting the swirl cone into the compression screw.

NOTE: Hold all the parts in a vertical position during reassembly.
6. Reinstall the nozzle housing over the swirl cone and compression screw.

NOTE: If threads do not screw back together smoothly, apply a small amount of silicone lubricant (REF: SS-103) to the compression screw threads.
7. Replace the o-ring if it was removed earlier.
8. Return the assembled nozzle to its original position in the instrument.
9. Repeat Steps 1 through 8 for each nozzle.
10. Perform a Volume Test (Section 6.4).
11. Perform a Hub Pattern Test (Section 6.6).

NOTE: You must perform the Hub Pattern Test and Volume Test before operating the instrument. If the results are incorrect, manually prime the instrument. If not staining immediately after Hub Pattern Test, it is recommended to run a clean cycle (see Section 2.2) to prevent concentrated reagent from sitting in the lines for extended periods of time.

SECTION 6
NOZZLE MAINTENANCE AND PERFORMANCE
6.3 Manual Priming

Use this procedure to remove any air blocks from the reagent lines.

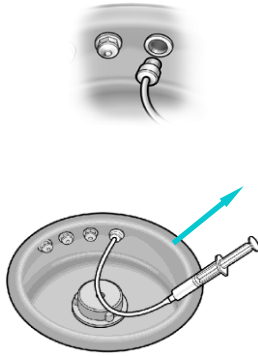

1. Remove the carousel from the bowl.
2. Remove the nozzle connected to the line to be manually primed.
3. Insert the priming tool nozzle adapter (included in the Nozzle Maintenance Kit) into the nozzle holder and turn it clockwise to install the adapter into the holder.
4. Withdraw the priming tool plunger halfway to create a vacuum. Hold the plunger in that position.
5. Press **Maintenance** from the Main menu.
6. Press **Volume Test**.
7. Press the desired prime button to start the reagent pump. As the line primes, pull back and relax the priming tool plunger multiple times, using caution not to fully remove.



WARNING!

Do not pull the plunger completely out of the priming tool. Pulling the plunger out of the tool may result in splashing or spraying of reagents. Do not push the plunger in while it is connected to the nozzle holder.

8. Discard the collected fluid into the stainer bowl.
9. It may be necessary to repeat steps 4–7 multiple times.
10. Once the reagent flows into the tube and is free of bubbles, press **Stop**.
11. Turn the nozzle adapter counterclockwise to remove it from the nozzle holder.
12. Reinstall the nozzle.
13. Perform a Volume Test.
14. Perform a Hub Pattern Test.

NOTE: *If staining will not be performed immediately, run a Clean Cycle (see Section 2.2) after Volume and Hub Pattern tests.*

SECTION 6

NOZZLE MAINTENANCE AND PERFORMANCE

6.4 Performing the Volume Test

The Volume Test requires the Nozzle Maintenance Kit.

NOTE: The Volume Test must be performed weekly.



1. From the Maintenance menu, select **Volume Test**.
2. Hold a Volume Test tube (small tube) angled down, covering the selected nozzle.
3. Press the corresponding reagent prime button to collect the reagent.
4. Read the volume once the collection is complete. Record on the PM chart (SS-265) or enter on the keypad if prompted by the software.
5. Repeat Steps 2 through 4 for each nozzle.
6. Compare collected nozzle volumes with the following table.

Table 12: Volume Test Tolerances

Nozzles/Reagent Lines	Minimum	Maximum
A, B, and C	9.0 mL	11.0 mL
D	8.5 mL	10.5 mL

NOTE: The stainer may function normally if nozzle volumes are slightly higher or lower than the specified range. It is important that the B and C nozzle volumes are similar, (typically within 1 mL). Spray volumes < 7.5 mL or > 13.0 mL indicate serious problems with the nozzles or reagent delivery lines.

- If the volume is within the tolerance range, go to Step 8.
 - If the volume is outside the tolerance range:
 - Clear the nozzle orifice with the nozzle brush found in the maintenance kit.
 - If necessary, remove the nozzle and perform the Nozzle Cleaning procedure (Section 6.1).
 - If the problem persists, replace the nozzle.
7. Prepare the Maintenance Kit for future use:
 - Empty the contents of the tubes into the stainer bowl.
 - Rinse the tubes with water.
 - Put the tubes back into their original place in the Maintenance Kit or tube stand.
 8. Press **Back** twice to return to the Main menu.

SECTION 6
NOZZLE MAINTENANCE AND PERFORMANCE
6.5 Performing the Slide Pattern Test

This test can differentiate poor staining results from sample preparation problems, or nozzle obstructions. Perform the Slide Pattern test when a Hub Pattern test produces a normal result, but staining is still inadequate.

1. Place a 1 x 3 inch (2.5 x 7.6 cm) piece of paper (REF: RP-500) in positions 1 and 2 of the carousel, with a blocking slide in front of positions 1 and 2.
2. Load the carousel into the stainer and close the lid.
3. From the Main menu, press **Maintenance**.
4. Press **Pattern Test**.
5. Press the corresponding prime button for the reagent line to be tested.
6. Remove the paper slides.
7. Repeat Steps 1 through 6 for each reagent line.
8. Examine the paper slides for each reagent. The pattern on the slide should be uniform, without any continuous lines or streaks (see Figures 10 and 11).

Figure 10: Correct Slide Pattern Test Result

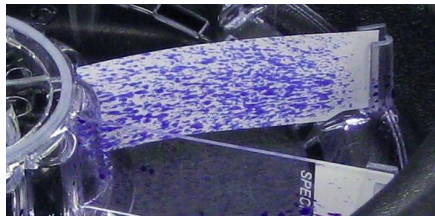
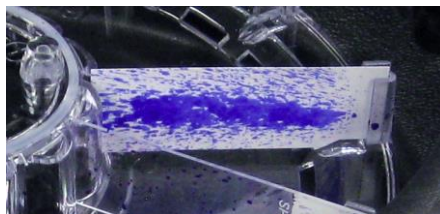

Figure 11: Incorrect Slide Pattern Test Result



9. If the pattern test results are incorrect, remove the nozzles and perform the nozzle cleaning procedure (Section 6.1). If the problem persists, contact Bruker Biomedical Systems' Service team.

NOTE: If staining will not be performed immediately, run a clean cycle (see Section 2.2) after Volume and Hub Pattern tests.

SECTION 6

NOZZLE MAINTENANCE AND PERFORMANCE

6.6 Performing the Hub Pattern Test

Use the Hub Pattern Test to ensure the nozzles are clear of debris and spraying properly.



1. From the Maintenance menu, Press **Pattern Test**.
2. Hold a sheet of absorbent paper near the drive hub, squarely facing the target nozzle.
3. Press the corresponding nozzle button.
4. Check the pattern (see Figures 12 and 13). If the pattern test results are incorrect, remove the nozzles and perform the nozzle cleaning procedure (Section 6.1). If the problem persists, contact Bruker Biomedical Systems' Service team.

Figure 12: Correct Hub Pattern Test Result



Figure 13: Incorrect Hub Pattern Test Result



NOTE: If not staining immediately after the Hub Pattern Test, it is recommended to run a clean cycle (see Section 2.2) to prevent reagent from sitting in the lines for extended periods of time.

SECTION 7
SOLVING PROBLEMS
7.1 Troubleshooting

The following table is to help identify and solve routine problems with the stainer. More difficult problems may require technical service. Contact your Bruker representative for assistance.



WARNING!

Due to the electrical shock hazard, do not open this instrument or attempt internal repairs. Refer servicing to qualified service personnel. Contact your dealer or Bruker Biomedical Systems' Service Team.

Table 13: General Troubleshooting and Diagnosis

Problem	Solution
There is no power to the stainer when the power switch is turned ON.	Check the facility outlet and the power cord connection. Check the fuses. Refer to the Replacing Fuses procedure. ⚠ CAUTION: Fuse failure may indicate a serious internal problem.
Strange information shows on the display, and/or erratic stainer operation.	Switch the power OFF , wait 10 to 20 seconds, then switch power ON again. If problem recurs, install a computer-type surge suppressor to protect the instrument from power line transients. If possible, connect the stainer to a power circuit that is not shared by centrifuges, refrigerators, air conditioners, or other motorized equipment. If the above steps do not solve the problem, contact your dealer or Bruker Biomedical Systems for assistance.
A reagent line will not prime when power is ON and you press the prime button.	Follow the procedures in Section 6.3 for priming reagent pumps.
A reagent line will not prime, even with the priming tool (Section 6.3).	Press the priming button and listen carefully for the sound of the pump. If you can hear the pump, try the priming tool again. If the problem is not solved or if you cannot hear the pump there may be an internal problem. Contact your dealer or Bruker Biomedical Systems for assistance.
Stainer bowl fills with reagent after use.	A small puddle of stain around the drain inlet or the bottom of the bowl is normal. If the bowl is filling with a large quantity of stain, check the external drain tube for blockage. Make sure the drain tube is properly connected and running continuously down toward the lab drain or vented waste container, with no loops, rises, or obstructions. Make sure the end of the tube is not submerged. This can prevent proper drainage. The internal drain may need to be cleaned or replaced. Contact your dealer or Bruker Biomedical Systems' Service Team.

SECTION 7
 SOLVING PROBLEMS
7.1 Troubleshooting

Table 13: General Troubleshooting and Diagnosis (continued)

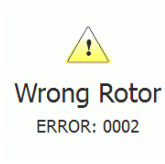
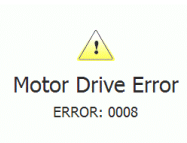
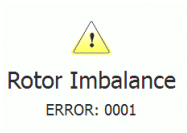
Problem	Solution
<p>Stain is leaking onto the counter.</p>	<p>Check all external reagent lines for visible signs of cracks or loose fittings.</p> <p>Make sure the drain outlet is not blocked.</p> <p>Make sure the drain tube is securely attached to the drain port and that the tubing is not cracked or deformed.</p> <p>Reagent leaks may indicate an internal problem (see Section 7.3). Contact your dealer or Bruker Biomedical Systems for further assistance.</p>
<p>Error messages are on the screen.</p> <div style="text-align: center; margin: 10px 0;">  </div> <div style="text-align: center; margin: 10px 0;">  </div> <div style="text-align: center; margin: 10px 0;">  </div>	<p>If the display shows Lid Not Shut: Verify that the lid is fully closed and latched. If the Lid Not Shut indication remains, contact Bruker Biomedical Systems for assistance.</p> <p>If the display shows Wrong Rotor after pressing Start: Make sure the slide carousel is properly loaded on the drive hub. In staining mode, the instrument detects whether the staining carousel is present before proceeding. In cytocentrifuge mode, the instrument will stop if it senses the staining carousel. After verifying the carousel is correctly loaded, press Start. If the display still shows Wrong Rotor, there may be an internal problem. Check for missing carousel magnets.</p> <p>The microprocessor monitors carousel rotation during a staining cycle. The display shows an error message if the rotation is not within the specified range.</p> <p>If the display shows Motor Drive Error: Check the stainer bowl for interference: Turn the hub or carousel by hand; it should turn freely.</p> <p>Drive motor or electronic component malfunctions require servicing of internal components. Contact your dealer or Bruker Biomedical Systems for assistance.</p> <p>If the display shows Rotor Imbalance, make certain the Cytopro rotor is balanced, or the staining carousel is seated correctly on the hub.</p> <p>See Electronic Failure later in this table.</p>

SECTION 7
SOLVING PROBLEMS
7.1 Troubleshooting

Table 13: General Troubleshooting and Diagnosis (continued)

Problem	Solution
<p>The stainer fails to spray reagent during a staining cycle and/or continues to run after the cycle should be complete.</p>	<p>To allow programmed staining of partial loads, the stainer monitors the position of the carousel as it rotates in the bowl. In normal operation, stain is sprayed only in the correct position. This causes the actual cycle time to vary, depending on the position of the carousel at the beginning of the cycle. However, if the cycle continues for an abnormally long period, or if the bar graph and percentage complete icon do not change after 1 minute, it may indicate an electronic problem or an internal problem. To determine this, press Stop.</p> <p>If the cycle stops: this indicates a problem with the carousel position sensor. Contact your dealer or Bruker Biomedical Systems' Service Team for assistance.</p> <p>If the cycle continues: this indicates an electronic problem (see below).</p>
<p>Abnormal staining on entire surface of all slides.</p>	<p>Check the reagent level on the display and/or in the reagent bottles.</p> <p>Make sure the external reagent dip tubes are securely attached to each bottle (Section 2.1).</p> <p>Open the lid and verify that each reagent pump is primed, by pressing the corresponding prime button. The nozzle should immediately spray a fine mist of reagent. There should be no sputtering or hissing sounds indicating air in the reagent lines.</p> <p>Watch the external tubes for air bubbles. Air bubbles indicate inadequate priming or possibly an air or reagent leak in the system. Air in any reagent line will cause poor staining.</p> <p>Check nozzle performance using the Slide Pattern (Section 6.5) and Volume Tests (Section 6.4). If necessary, clean nozzle(s) using the procedures in Section 6.1.</p> <p>Verify that each reagent dip tube vent hole is clear. When staining a full carousel (7 or more slides) make certain you have not programmed the stainer for fewer slides.</p> <p>If staining a partial load, load the slides in the correct positions as indicated by the markings on the carousel (see Section 4.1).</p>

SECTION 7
 SOLVING PROBLEMS
7.1 Troubleshooting

Table 13: General Troubleshooting and Diagnosis (continued)

Problem	Solution
Abnormal staining on entire surface of all slides (continued).	Confirm slides are loaded in the correct direction, with the sample facing as indicated by the arrows on the bottom of the carousel. Slides loaded in the wrong direction will receive a reduced amount of stain and can result in an abnormal appearance (see Section 4.1).
Abnormal staining on entire surface of some slides, while other slides from the same carousel appear normal.	<p>Make certain that all position magnets are still attached to the bottom of the carousel. Make certain you have not programmed the stainer for fewer slides than you have loaded.</p> <p>If you program the stainer for a partial load, load the slides in the correct positions as indicated by the markings on the carousel (see Section 4.1).</p> <p>Verify that each reagent pump is primed by opening the lid and pressing the corresponding prime button. The nozzle should immediately spray a fine mist of reagent. There should be no sputtering or hissing sounds to indicate the presence of air in the reagent lines (see Section 7.3).</p>
Streaks or bands of discoloration on one or more slides.	<p>Check the level of the Rinse (Reagent A) bottle. Check Rinse (Reagent A) spray volume according to Section 6.4.</p> <p>Check nozzle spray pattern according to the procedures in Sections 6.5 and 6.6. This type of discoloration is usually caused by debris or reagent precipitate clogging the spray nozzle orifice.</p> <p>Clean any nozzle that exhibits a poor spray pattern.</p>
Cells are washing off slides.	<p>Check methanol or Aerofix (Reagent D) level in bottle.</p> <p>Check Reagent D nozzle spray volume and slide pattern (see Section 6.4 and Section 6.5).</p> <p>Check the methanol or Aerofix (Reagent D) hub pattern and spray volume (see Sections 6.5 and 6.6).</p> <p>Make certain the blood smears are completely dry and not too thick (see Section 7.2).</p> <p>Increase the fixation setting to High.</p> <p>Call Bruker Biomedical Systems for information on slide quality.</p>
Refractile artifacts are observed in erythrocytes.	Refer to Section 7.2.
High levels of precipitates observed.	Discard leftover thiazin stain (Reagent B) in the used bottle when changing to a fresh bottle of stain. While transferring remaining stain saves stain, it eventually concentrates the precipitates to the point they appear on the slide.

SECTION 7
SOLVING PROBLEMS
7.1 Troubleshooting

Table 13: General Troubleshooting and Diagnosis (continued)

Problem	Solution
Staining intensity is too weak/granulation is weak.	<p>Increase the intensity setting.</p> <p>Confirm slides are loaded in the correct direction, with the sample facing as indicated by the arrows on the bottom of the carousel. Slides loaded in the wrong direction will receive a reduced amount of stain and can result in an abnormal appearance (see Section 4.1).</p>
Refractile artifacts are observed in erythrocytes when using Basofix predip (SS-049P).	<p>Mix 1 part Aerofix (SS-048) with 3 parts Basofix predip (SS-049P), or add 5 mL Aerofix concentrate (SS-148) to 500 mL Basofix predip (SS-049P).</p>
Increased false-positives for Howell-Jolly bodies or amorphous precipitates are observed.	<p>Disinfect reagent lines using instructions in Section 7.2.</p> <p>Discard leftover thiazin stain (Reagent B) in the used bottle when changing to a fresh bottle of stain. While transferring remaining stain saves stain, it eventually concentrates the precipitates to the point where they can be seen on the slide.</p>
Electronic failure	<p>An electronic failure would appear as an obvious malfunction such as a scrambled or totally inoperative display panel.</p> <p>Transient voltages coming through the power lines may cause the stainer to “lose its place.”</p> <ol style="list-style-type: none"> 1. If this occurs, switch the main power OFF for 10-20 seconds and then back ON to reset the instrument. 2. If the problem recurs, install a computer-type surge protector to isolate the instrument. 3. If possible, connect the stainer to a power circuit not shared by centrifuges, refrigerators, air conditioners, or other motorized equipment. <p>For more obscure electronic problems, monitor the stainer through a complete staining cycle to determine if the operating sequence is correct. Do this by running the stainer while watching the display and listening to the pumps.</p> <p>Ensure that each event occurs according to the operating sequence, shown in Table 3 in Section 1.</p> <p>If the problem recurs, contact your dealer or Bruker Biomedical Systems for assistance.</p>

SECTION 7 SOLVING PROBLEMS

7.2 Abnormal Staining Results

Smear Separation or Tearing

Losing blood cells from the slide surface during a staining cycle can happen for several reasons:

Improper Alcohol Fixation

If the alcohol-fix phase of the cycle fails, there will be cell loss when stain is applied. Verify that the alcohol nozzle is operating properly with normal spray pattern and spray volume (Sections 6.4, 6.5). To identify the problem as a fixation failure, fix some specimen slides in methanol prior to loading into the carousel. Select a fixation setting that increases fixation (9).

Wet Smears

Loading wet blood smears into the carousel may contribute to smear tearing. Allow smears to dry for several minutes before beginning a stain cycle.

Thick Smears

Smears that are too thick can cause smear separation. If the smear has a thick “wedge” cross section, cells can be torn away from the slide surface in the thicker regions, while the thinner “monolayered” regions remain usable. Severe tearing that starts in the thick region may also extend into the monolayer.

Dirty Slides

Dirty slides are a major source of cell loss during staining. We strongly recommend that you use new, premium quality slides. Even with premium quality slides, random loss may occur due to inadequate slide surface quality. When the stainer is functioning properly, slide quality accounts for most, if not all, cell loss problems.

Red Cell Artifacts

Red cell artifacts, often called water artifacts, drying artifacts, water spotting, or refractile artifacts, can occur in any lab. Several factors may contribute to their formation, including moisture in the fixative, ambient humidity, not allowing the blood to dry completely on the slide, the thickness of the blood smear, and even individual patient samples, as some blood may naturally be more prone to artifact formation.

Fixation is a critical step in slide preparation that serves multiple purposes. It adheres cells to the slide and preserves cellular structure by replacing water with alcohol. This process also minimizes artifacts by facilitating the evaporation of water from the cells, resulting in a cleaner slide.

If extensive artifacts are covering the red blood cells, the following measures can help reduce them:

7.2 Abnormal Staining Results

- **Use fresh anhydrous methanol or Aerofix®**
If the methanol or Aerofix being used has absorbed too much water, it may not be drying the water on the slides quickly enough, resulting in more artifacts. Using fresh methanol or Aerofix® may help.
- **Use high fixation**
Increasing the fixation to High may reduce water spotting by applying more fixation to the slides, which may result in fewer artifacts.
- **Wipe the bowl dry**
Between cycles, leave the stainer lid open to allow the bowl to dry out. If necessary, wipe the interior of the bowl dry to reduce relative humidity.
- **Manually fix the slides**
Water spotting may be reduced by manually fixing the slides in anhydrous methanol for 3–5 minutes before loading them into the carousel. Allow the slides to dry before staining.

False-Positive Howell-Jolly Bodies or Amorphous Precipitates

Artificial Howell-Jolly bodies may be caused by precipitate build up from transferring the residual thiazin stain (Reagent B) to the fresh bottle when reloading reagents.

If such artifacts are encountered, use methanol or decontamination solution (REF: SS-133) to disinfect the reagent lines and pumps.

Replace precipitated stain with fresh stains after flushing the lines.

Procedure:

NOTE: Do not remove the nozzles.

1. Place all dip tubes into methanol or decontamination solution.
2. Press **60-Sec Prime** on each reagent line to pump prepared solution through each affected reagent line (A, B and C). Repeat this step and wait 20 minutes.
3. Pump another 100 mL of disinfectant solution through each affected reagent line and let sit for 20 minutes.
4. Flush each affected reagent line with 150 mL of deionized water.
5. Reprime the stainer with fresh reagents (see Section 2.2) and clean nozzles according to instructions in Section 6.1 and 6.2.

SECTION 7 SOLVING PROBLEMS

7.3 Instrument Malfunction

Inconsistent Reagent Flow

When the instrument is operating correctly, a smooth and continuous liquid spray will come from the nozzles. Repriming the instrument is usually unnecessary, however, the following situations may occur, which require repriming (see Section 6.3):

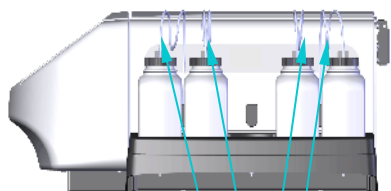

Reagent Delivery Lines



- **Reagent bottle runs dry.**
- **Extended idle time.** If the instrument has been sitting idle for an extended period of time, air pockets may occur.
- **Hardware failure.**
 - Carefully inspect all components in the external reagent delivery lines. Look for loose connections, cracks, or breaks that might allow air to be drawn in when the pump operates. Replace any defective part or assembly.
 - An internal leak may cause fluid to leak from the line when the pump is not running. If an abnormal liquid spray still occurs after all the external reagent delivery line components have been verified, the instrument may require further investigation. Contact your dealer or Bruker Biomedical Systems' Service team for assistance.
 - A reagent line leak between the pump outlet and the nozzle will cause fluid to leak into the interior of the stainer housing and ultimately onto the counter. If you observe this, the instrument will require service. Contact your dealer or Bruker Biomedical Systems' Service team for assistance.



WARNING!

A break or malfunction in the reagent delivery system can potentially release up to 500 mL of highly flammable alcohol in and around the instrument. If this occurs, carefully shut off the power to the instrument and consult the SDS for information in handling alcohol spills. Do not use the instrument again until any leaks are repaired.







WARNING!

Electrical shock hazard—do not open this instrument or attempt internal repairs. Refer servicing to qualified service personnel. Contact your dealer or Bruker Biomedical Systems' Service Team.

7.3 Instrument Malfunction

Reagent Level Detect System Errors

The Reagent Level Detect System may show the following conditions. Refer to Section 2.2 for zeroing as needed.

Icon	Condition	Resolution
	Reagent bottle empty	Replace bottle.
	Measurement error (such as external bottle unplugged or internal level detect problem)	Reseat connector, check for wear. Replace as needed.
	Reagent has exceeded expiration date (enabled from QC Maintenance menu)	Replace expired bottle. Update lot and expiration date.
	Waste bottle error (such as external bottle unplugged)	Reseat connector, check for wear. Replace as needed.
	Waste bottle full	Empty bottle.

If the issue persists and zeroing (Section 2.2) does not correct the problem, calibrate the system as follows:



1. Press **System Information** from the Main menu.



2. Press **System Setup**.



3. Press **Level Detect**.

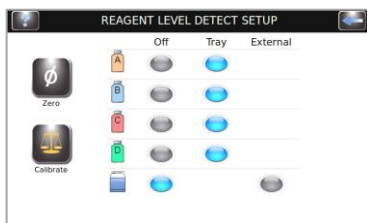

4. Press **Calibrate**. Follow the display prompts.

SECTION 7
SOLVING PROBLEMS
7.3 Instrument Malfunction



5. Remove all reagent bottles and press **Start**.



NOTE: Any vibrations or bumps to the instrument or lab bench can cause inaccuracies in zeroing or calibration.



6. Place the correct reagent bottles in all **enabled** positions, and press **Start**.

NOTE: Calibration requires full, unopened (caps and seals in place) 500 mL bottles of reagent, placed in the correct tray positions (due to different densities of each reagent type).



NOTE: The calibration function ignores any disabled reagent line.



7. Press **OK**. Press **Back** twice to return to the Main menu.

8. Return the reagent bottles to the tray as indicated in Section 2.1 to prepare for staining.

NOTE: For accurate reagent level detection and calibration, dip tubes must follow their pre-formed coiled shapes.

7.4 Calibrating the Touchscreen



1. Press and hold **Standby/Ready** for 5 seconds. A calibration screen with a target appears.
2. Press the center of the target with a finger, stylus, or similar tool. Another target will appear in a different location.
3. Continue to press the center of the targets until you have pressed all the targets (five total). After the fifth target is pressed, the instrument will save the touch screen calibration and return to the Main menu.

SECTION 7 SOLVING PROBLEMS

7.5 Service Information

Bruker Biomedical Systems' Service Department will help you resolve any questions about the operation or performance of your Aerospray Stainer/Cytocentrifuge.

Customers in the United States should contact us by telephone. Outside the U.S., our authorized dealers offer full local service and support.



ELITechGroup Inc.

370 West 1700 South
Logan, Utah 84321 USA

Telephone:

800 453 2725 (United States & Canada)
(+1) 435 752 6011 (International calls)

Fax:

(+1) 435 752 4127

Email:

Service.bms@bruker.com

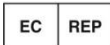

European Authorized Representative:

MT Promedt Consulting
Ernst-Heckel-Straße 7
66386 St. Ingbert
Germany

Telephone: +49(0)68 94-58 10 20

Fax: +49(0)68 94-58 10 21

Email: info@mt-procons.com



Swiss Authorized Representative:

Decomplic AG
Freiburgstrasse 3
3010 Bern
Switzerland
Telephone: +41 32 365 33 33
Email: sar@decomplic.com

SECTION 8
CYTOPRO® CYTOCENTRIFUGE
8.1 Cytopro Cytocentrifuge Information

Functional Description

The Cytopro Cytocentrifuge rotor allows rapid sedimentation of specimen cells onto microscope slides for staining or other purposes. Up to eight disposable/reusable sample chamber assemblies with absorbent pads and glass microscope slides can be loaded into the Cytocentrifuge rotor.

Cytocentrifuge and staining functions are independent of one another.

The Cytopro rotor reduces cell loss during collection and prevents accidental damage to the collected specimen. The rotor is sealed to control aerosol release during cytocentrifugation. See the Cytopro Rotor Applications Manual (Aerospray Models 7xx2) (RP-517) for complete information.

Key Features

Adding the Cytopro Cytocentrifuge rotor transforms the stainer into a standard cytocentrifuge with:

- Single, Dual, and Cytopro Magnum chambers
- Reusable or disposable chambers (single and dual)
- Holds eight slides and chambers
- User-programmable memory locations for settings (speed, acceleration rate, and time)
- Easy switching between staining and cytocentrifuge modes
- Autoclavable rotor

NOTE: Pressing **Cyto** brings up the Cytocentrifuge mode. Pressing **Back** returns to stain mode.



WARNING!

The Cytopro rotor lid, rotor gaskets and related components are intended to be part of biosafety system as specified in international and national biosafety guidelines. They cannot be relied on as the only means of safeguarding workers and the environment when handling pathogenic microorganisms.

Intended Use

The Cytopro Cytocentrifuge rotor is an in vitro diagnostic medical device for professional use only. It is an accessory for fixing biological cell suspensions on glass microscope slides for cytological examination.

The Cytocentrifuge rotor can be used with the following cell suspensions:

- Bronchoalveolar liquid (BAL)
- Cerebrospinal fluid (CSF)
- Urine
- Synovial fluid
- Others

APPENDIX A

Critical Reagent Components



The following information identifies the critical chemicals of each reagent used in this instrument.

Reagent(s)	Critical Components
SS-035A, SS-035A-EU, SS-035AG, or SS-135/149A (as diluted) Hematology Reagent A Rinse contains:	<1% Potassium Phosphate <1% Sodium Phosphate <1% Eosin <1% Benzyl Alcohol
SS-035/049B, SS-035/049B-EU, SS-035/049BG, or SS-135/149B (as diluted) Hematology Reagent B Thiazin Stain contains:	<1% Potassium Phosphate <1% Sodium Phosphate <1% Azure B <1% Methylene Blue <1% Benzyl Alcohol <0.1% Tergitol TMN 100X
SS-035C, SS-035C-EU, SS-035CG, or SS-135/149C (as diluted) Hematology Reagent C Eosin Stain contains:	<1% Potassium Phosphate <1% Sodium Phosphate <1% Eosin <0.2% Formaldehyde <0.1% Tergitol TMN 100X
SS-048, or SS-148 (as diluted), SS-148-EU Aerofix Fixative High Humidity contains:	>95% Methyl Alcohol <4% Ethylene Glycol <2% Polyvinylpyrrolidone (PVP) <1% Azure B
SS-049A, SS-049A-EU, or SS-135/149A (as diluted) Basofix Reagent A contains:	<3% Ethyl Alcohol <3% Methyl Alcohol <1% Potassium Phosphate <1% Sodium Phosphate <1% Eosin < 0.2% Formalin
SS-049C, SS-049C-EU, or SS-135/149C (as diluted) Reagent C Basofix Eosin Stain contains:	<10% Diethylene Glycol <5% Ethyl Alcohol <5% Methyl Alcohol <1% Potassium Phosphate <1% Sodium Phosphate <1% Eosin Y
SS-049P, SS-049P-EU, or SS-149P (as diluted) Basofix Pre-dip Fixative contains:	<99% Methyl Alcohol <1% Polyvinylpyrrolidone <1% Azure B
SS-135/149A, Reagent A Rinse Reagent Concentrate contains:	<1% Potassium Phosphate <1% Sodium Phosphate <0.2% Formalin <1% Eosin
SS-135/149B, Reagent B Thiazin Stain Concentrate contains:	<10% Potassium Phosphate <10% Sodium Phosphate <2% Azure B <1% Methylene Blue

APPENDIX A
Critical Reagent Components

Reagent(s)	Critical Components
SS-135/149C, Reagent C Eosin Stain Concentrate contains:	<10% Potassium Phosphate <10% Sodium Phosphate <0.2% Formaldehyde <3% Eosin
SS-135S Surfactant contains:	<70% Germall II (Diazolidinyl Urea) <5% Tergitol TMN 100X
SS-148 or SS-148-EU, Aerofix Fixative Concentrate High Humidity contains:	55-70% Ethylene Glycol 30-45% Polyvinylpyrrolidone (PVP) <1% Azure B
SS-148 or SS-148-EU, Aerofix Fixative Concentrate High Humidity contains:	40-50% Methyl Alcohol 1-5% Oxalic Acid
SS-029, Nozzle Cleaning Solution Concentrate	40-55% Methanol 1-5% Oxalic Acid
SS-029C, Nozzle Cleaning Solution Concentrate contains:	95-99% Deionized Water 1-5% Oxalic Acid
SS-133 Decontamination Solution when diluted as directed contains:	<0-4% Germicidal Detergent >99% Deionized Water
SS-MEOH Anhydrous Methanol contains:	≥99.5% Methyl Alcohol, Anhydrous
SS-133 Decontamination Solution Concentrate contains:	<50% Germicidal Detergent >50% Deionized Water

APPENDIX B

Stain Information

Stain Description

The stains listed in this IFU are for use with the Aerospray Hematology Stat Slide Stainer/Cytocentrifuge for use by medical professionals to stain specimens as a step of standard laboratory practice in diagnosing disease.

Stain Composition

Critical components of stains and cleaning solutions used with this instrument are listed in Appendix A.

Storage and Shelf Life

- Stains and cleaning solutions are stable up to the expiration date indicated on the label.
- Stains and cleaning solutions should be stored 15–30 °C unless otherwise stated on the label.
- Once opened, stains are stable for 90 days.

Hazards and Precautions

The stains and cleaning solutions used with the Aerospray Hematology Stat Slide Stainer/Cytocentrifuge have been classified according to the following standards:

- Globally Harmonized System (GHS) United States Classification
- Regulation (EC) 1272/2008 Classification, Labelling and Packaging of Substances and Mixtures (CLP)

Information for each stain and cleaning solution regarding signal words, hazard classification, hazard pictograms, hazard and precautions statements can be found in the applicable Safety Data Sheet (SDS) for each stain or cleaning solution as well as the product labeling.

SDS for all stains and cleaning solutions can be requested from Bruker Biomedical Systems' Service Team or can be obtained by accessing the following website:

elitechgroup.com/documentation

APPENDIX C

Accessories and Supplies

Only replacement parts supplied by Bruker should be used in this instrument. Use of non-approved parts may affect the performance and safety features of this product.

ACCESSORIES	REFERENCE NUMBER
Aerospray® 12-Slide Carousel	AC-188
Cytopro Cytocentrifuge Rotor	AC-160
STAINS AND CLEANING REAGENTS	
Aerospray® Hematology Stat Reagent A, Rinse, 500 mL	SS-035A or SS-035A-EU
Aerospray® Hematology Stat Reagent A, Rinse, 1 gal	SS-035AG
Aerospray® Hematology Stat Reagent B, Thiazin Stain, 500 mL	SS-035/049B or SS-035/049B-EU
Aerospray® Hematology Stat Reagent B, Thiazin Stain, 1 gal	SS-035/049BG
Aerospray® Hematology Stat Reagent C, Eosin Stain, 500 mL	SS-035C or SS-035C-EU
Aerospray® Hematology Stat Reagent C, Eosin Stain, 1 gal	SS-035CG
Aerospray® Hematology Stat Reagent D, Aerofix® Fixative High Humidity, 500 mL	SS-048
Aerospray® Hematology Stat Reagent D (Methanol), 500 mL	SS-MEOH
Aerospray® Hematology Stat Reagent A (Basofix™ Rinse), 500 mL	SS-049A or SS-049A-EU
Aerospray® Hematology Stat Reagent B (Thiazin Stain), 500 mL	SS-035/049B or SS-035/049B-EU
Aerospray® Hematology Stat Reagent C (Basofix™ Eosin Stain), 500 mL	SS-049C or SS-049C-EU
Aerospray® Hematology Stat Basofix™ Pre-dip Fixative, 500 mL	SS-049P or SS-049P-EU
Aerospray® Hematology Stat Reagent A, Rinse, Concentrate, 135 mL	SS-135/149A
Aerospray® Hematology Stat Reagent B, Thiazin Stain, Concentrate, 135 mL	SS-135/149B
Aerospray® Hematology Stat Reagent C, Eosin Stain, Concentrate, 135 mL	SS-135/149C
Aerospray® Hematology Stat Surfactant (used with SS-135 A, B, C)	SS-135S
Aerofix® Additive for Reagent D (Methanol), 135 mL	SS-148 or SS-148-EU
Basofix™ Pre-dip Concentrate	SS-149P
Aerospray® Nozzle Cleaning Solution, 355 mL	SS-029
Aerospray® Nozzle Cleaning Solution Concentrate, 250 mL	SS-029C or SS-029C-EU
Decontamination Solution Concentrate	SS-133
Aerospray® Stain Residue Solvent,	SS-230 or SS-230-EU
PM Cleaning Solution	SS-266 or SS-266-EU
SUPPLIES	
Nozzle Tool	AC-034
Nozzle Hex Wrench	AC-035
5 L Space-Saver Container w/cap (For Concentrate Reagents)	AC-038
Drain Tube, 1.8 meter (6 foot) Length	AC-041
500 mL bottle with cap (pack of 5 bottles)	AC-043-05
Nozzle Orifice Cleaning Wire	AC-059
Reagent Pump Priming Tool	AC-069
Aerospray/Cytopro Safety Shield	AC-110
10 L Waste Container (without level detect)	AC-170
1D Barcode Scanner	AC-181
10 L Waste Container (with level detect)	AC-182
Nozzle Maintenance Kit	AC-184
2D Barcode Scanner	AC-185
O-Ring/Nozzle Thread Grease (3 grams)	SS-103
Preventive Maintenance Chart, pad of 24 sheets	SS-265
Aerospray Hematology Stat (Model 7122) Applications Manual	RP-460
Paper Test Slides	RP-500

APPENDIX D

Cleaning Solutions

Bruker offers several cleaning solutions for the Aerospray Stainer/Cytocentrifuge family. The following products are available to keep your Aerospray running safely and optimally.

SS-029 and SS-029C/SS-029C-EU Aerospray® Nozzle Cleaning Solution

Aerospray Nozzle Cleaning Solution (SS-029) and Aerospray Nozzle Cleaning Solution Concentrate (SS-029C/SS-029C-EU) when diluted as recommended should be used for cleaning the instrument. Specifically for:

- General cleaning
- Nozzle cleaning
- Instrument interior and exterior cleaning
- Carousel cleaning

The Aerospray Nozzle Cleaning Solution may be purged through the instrument pumps without causing damage to the instrument.

Dilution instructions for the Aerospray Nozzle Cleaning Solution Concentrate (SS-029C/SS-029C-EU) can be found by referring the instructions in **BMS-57-2010-01**.

SS-133 Decontamination Solution Concentrate

Decontamination Solution Concentrate (SS-133) when diluted as recommended should be used for decontamination of the inner and outer surfaces before the instrument is returned to Bruker Biomedical Systems for service or when instrument will be prepared for long-term storage.

SS-222 Aerospray® Line Cleaner

Aerospray Line Cleaner (SS-222) may be used if needed or if recommended by Bruker Biomedical Systems service personnel to clean out the stainer lines.

Aerospray Line Cleaner can be purged through pumps without causing damage to the instrument.

Contact Bruker Biomedical Systems' Service Team for more information.

SS-230/SS-230-EU Aerospray® Stain Residue Solvent

The Aerospray Stain Residue Solvent (SS-230/SS-230-EU) is for exterior cleaning of the nozzles, carousels, and bowls of Aerospray Slide Stainers. The Aerospray Stain Residue Solvent can be used as a cosmetic cleaner for the outside of the instrument, sinks, floors, counter tops, etc.



WARNING!

Do not run Aerospray Stain Residue Solvent (SS-230/SS-230-EU) through stainer pumps as serious damage will result to the instrument. This solvent is for the exterior cleaning of nozzles, carousels and bowls for Aerospray slide stainers only.

APPENDIX D Cleaning Solutions

SS-266/SS-266-EU Aerospray® PM Cleaning Solution

Aerospray PM Cleaning Solution (SS-266/SS-266-EU) can be used for cleaning the instrument when performing preventive maintenance on the instrument. The Aerospray PM Cleaning Solution is recommended for nozzle cleaning especially for nozzles that have stubborn contamination.

The Aerospray PM Cleaning Solution may be purged through the instrument pumps without causing damage to the instrument.

See Section 5 of this IFU for information on preventive maintenance procedures.

SS-MEOH Aerospray® Reagent Grade Methanol

Aerospray Reagent Grade Methanol (SS-MEOH) can be used for general exterior and internal cleaning of the instrument and pumps. Refer to the relevant sections in this IFU for its applicable use.

Revision History

REF. NUMBER	RELEASE DATE	CHANGE SUMMARY
BMS-57-2000-03A	2026-02-10	<ul style="list-style-type: none">• Added Bruker branding to cover and back page• Rebranded site name from “ELITechGroup” to “Bruker Biomedical Systems”• Changed document name from “Applications Manual” to “Instructions for Use”• Updated Preventive Maintenance section• Added Annual Maintenance section• Added information about water spotting• Corrected order of Staining Protocol (Section 4)• Updated Troubleshooting section• Added clarifying notes• Corrected minor errors



ELITechGroup Inc.
370 West 1700 South
Logan, Utah 84321, USA

1.800.453.2725

www.elitechgroup.com

REF BMS-57-2000-03A